

# NeuroImaging Data Processing

aka. Statistical Parametric Mapping short course

Course 1 & 2:  
spatial pre-processing

# SPM work flow

Image time-series

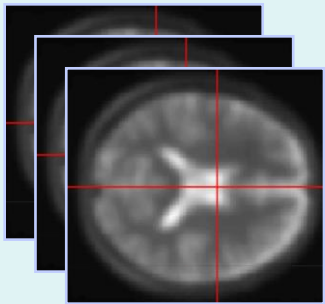

Spatial filter

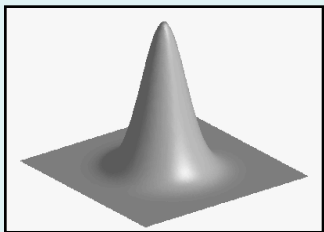

Realignment

Smoothing

General Linear Model

Statistical Parametric Map

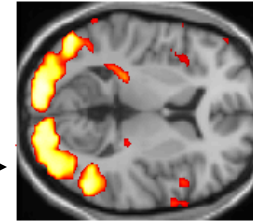
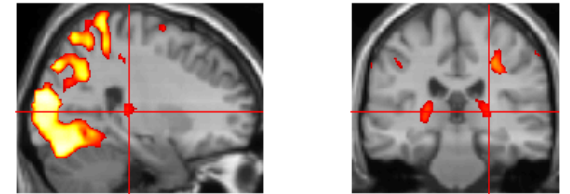

Normalisation

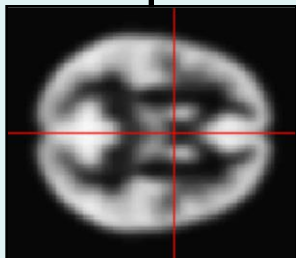

Anatomical reference

Design matrix

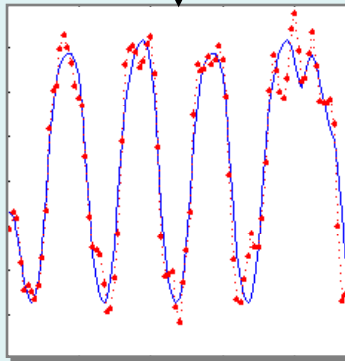
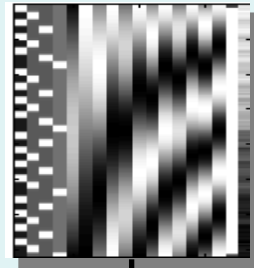

Parameter estimates

Statistical Inference

RFT

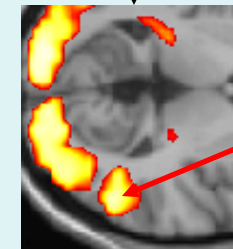

$p < 0.05$

# Content

---

- **Preliminaries**
- **Within-subject**
- **Between-subject**
- **Smoothing**
- **Conclusion**

# Content

---

- **Preliminaries**

- **Introduction**
- **Rigid-body & affine transformation**
- **Function optimisation**
- **Transformations and interpolation**
- **Pre-processing overview**

- **Within-subject**

- **Between-subject**

- **Smoothing**

- **Conclusion**

# Image registration

---

Most “spatial pre-processing” involves aligning images together.

## **Two components:**

- *Registration* –  
i.e. Optimise the parameters that describe spatial transformations between the images.
- *Transformation* –  
i.e. Re-sample according to the determined transformation parameters.

# *Label based techniques*

---

- Homologous labels (points, lines, surfaces) in the source and the reference images
  - find transformations that best superpose them
- Labels are identified (manually/semi-automatically)
  - time consuming and subjective process
  - few identifiable discrete points in the brain
- Lines and surfaces, e.g. contours, can be extracted (semi-)automatically
- Best match = minimal **distance**  
Question: how do you measure "distance"?

# *Label based* techniques

- Homologous labels (points, lines, surfaces) in the source and the reference images
  - find transformations that best superpose them



Not so obvious in the brain!

# *Intensity based* techniques

---

By minimizing a “**distance**” between the whole *source* image and the whole *reference* image:

- Need a scalar measure (=distance) to optimize
- Depends on the image content...

Finding a best match = global optimum?

- but susceptible to poor starting estimates

Hybrid approaches :

1. label/manual, then
2. intensity based methods



# Optimisation

- Image registration is done by **optimisation**.
- Optimisation involves finding some “best” parameters according to an “objective function” (to be either minimised or maximised)

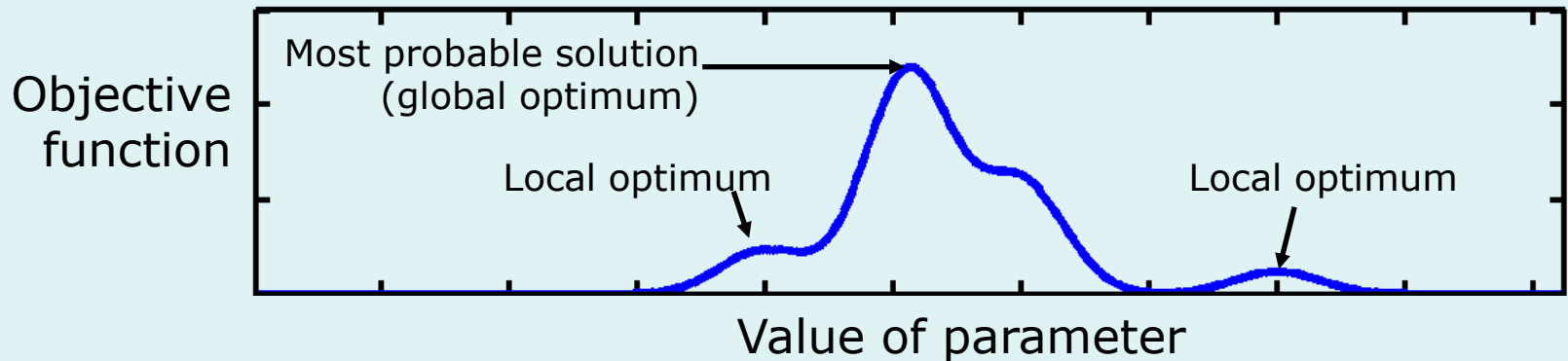

# Optimisation, multiple parameters

---

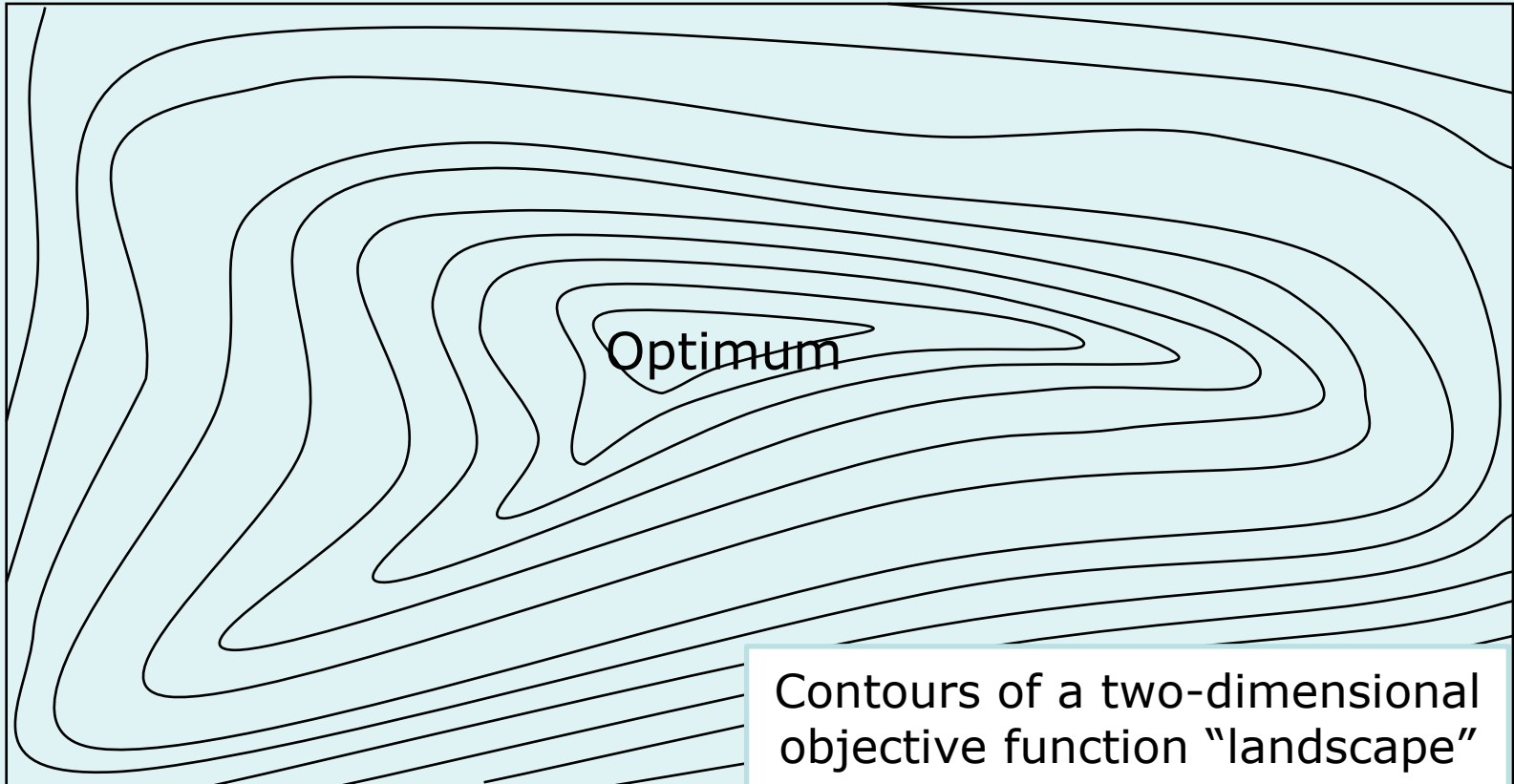

No grid exploration at "high dimension" !

# Optimisation

Because registration only finds a *local optimum*, some manual reorienting of the images may be needed before doing anything else in SPM.

An MNI-space image from `spm12/canonical` directory.

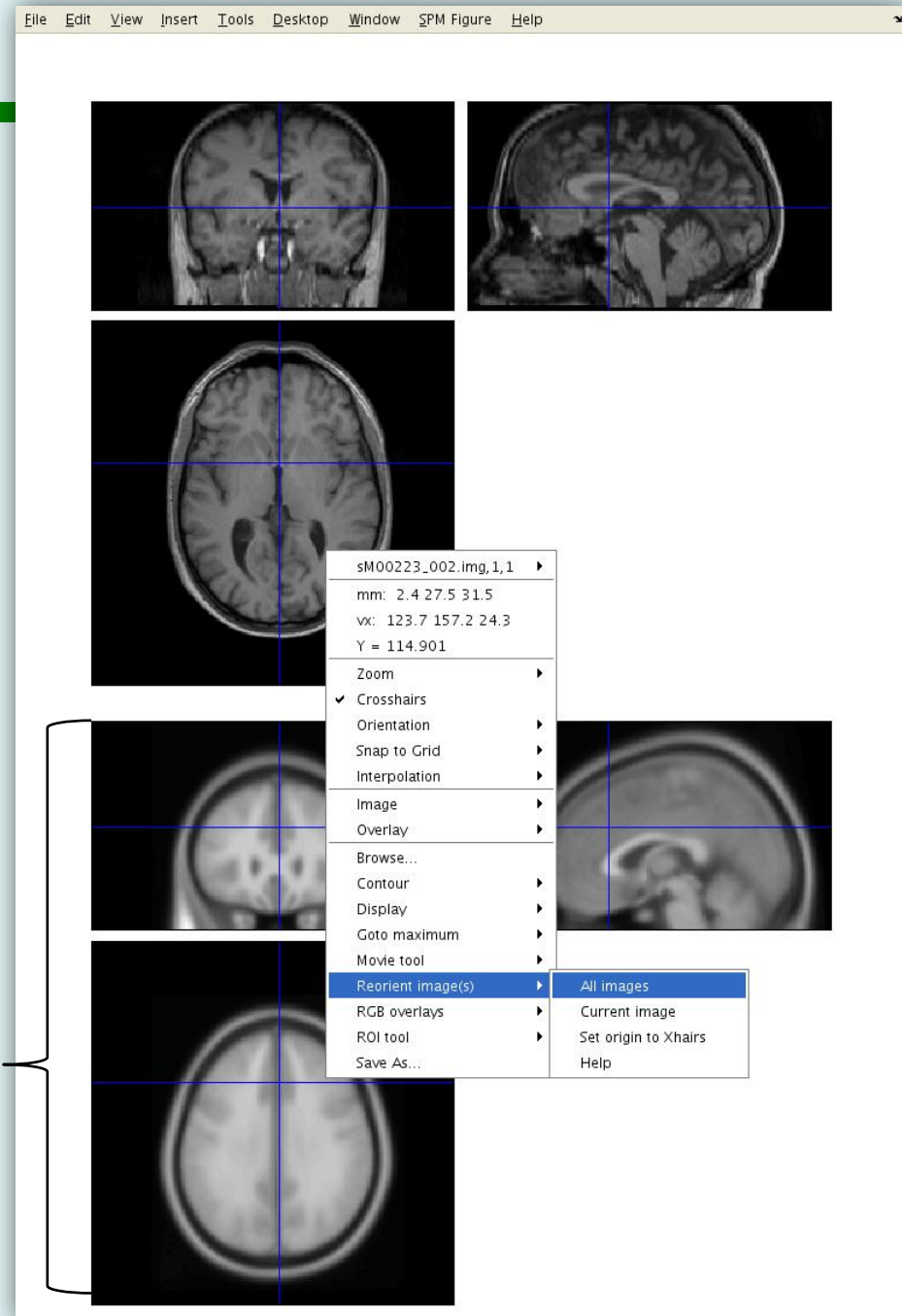

# 2D Affine Transforms

- Translations by  $t_x$  and  $t_y$

$$x_1 = x_0 + t_x$$

$$y_1 = y_0 + t_y$$

- Rotation around the origin by  $\Theta$  radians

$$x_1 = \cos(\Theta) x_0 + \sin(\Theta) y_0$$

$$y_1 = -\sin(\Theta) x_0 + \cos(\Theta) y_0$$

- Zooms by  $s_x$  and  $s_y$ :

$$x_1 = s_x x_0$$

$$y_1 = s_y y_0$$

- Shear  $h_x$

$$x_1 = x_0 + h_x y_0$$

$$y_1 = y_0$$

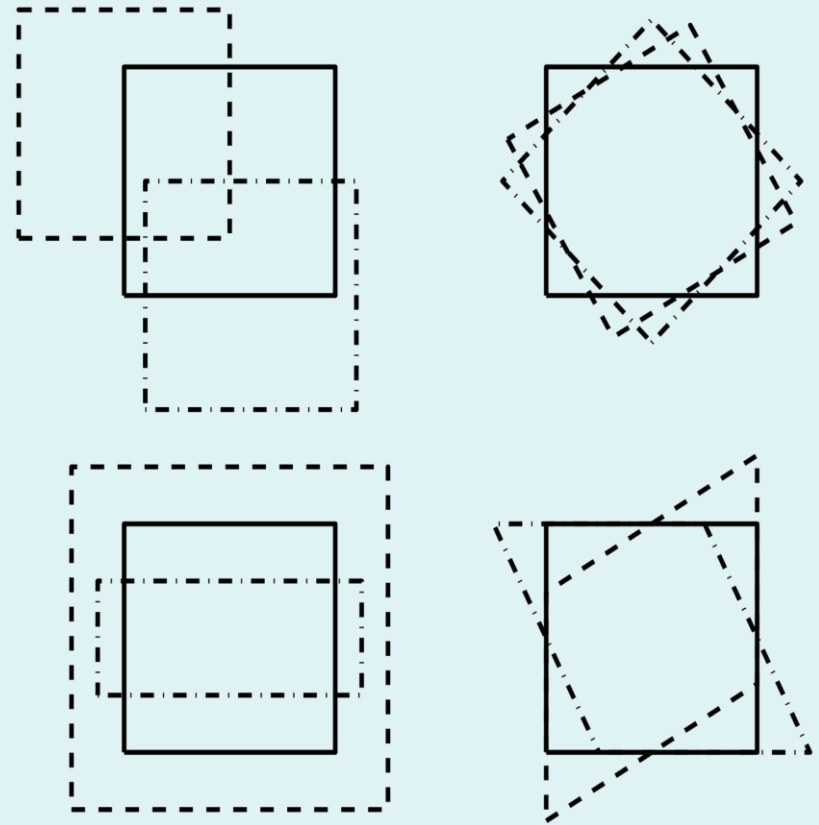

Same for  $h_y$

# 2D Affine Transforms

- Translations by  $t_x$  and  $t_y$

$$x_1 = 1 x_0 + 0 y_0 + t_x$$

$$y_1 = 0 x_0 + 1 y_0 + t_y$$

- Rotation around the origin by  $\Theta$  radians

$$x_1 = \cos(\Theta) x_0 + \sin(\Theta) y_0 + 0$$

$$y_1 = -\sin(\Theta) x_0 + \cos(\Theta) y_0 + 0$$

- Zooms by  $s_x$  and  $s_y$ :

$$x_1 = s_x x_0 + 0 y_0 + 0$$

$$y_1 = 0 x_0 + s_y y_0 + 0$$

- Shear  $h_x$

$$x_1 = 1 x_0 + h_x y_0 + 0$$

$$y_1 = 0 x_0 + 1 y_0 + 0$$

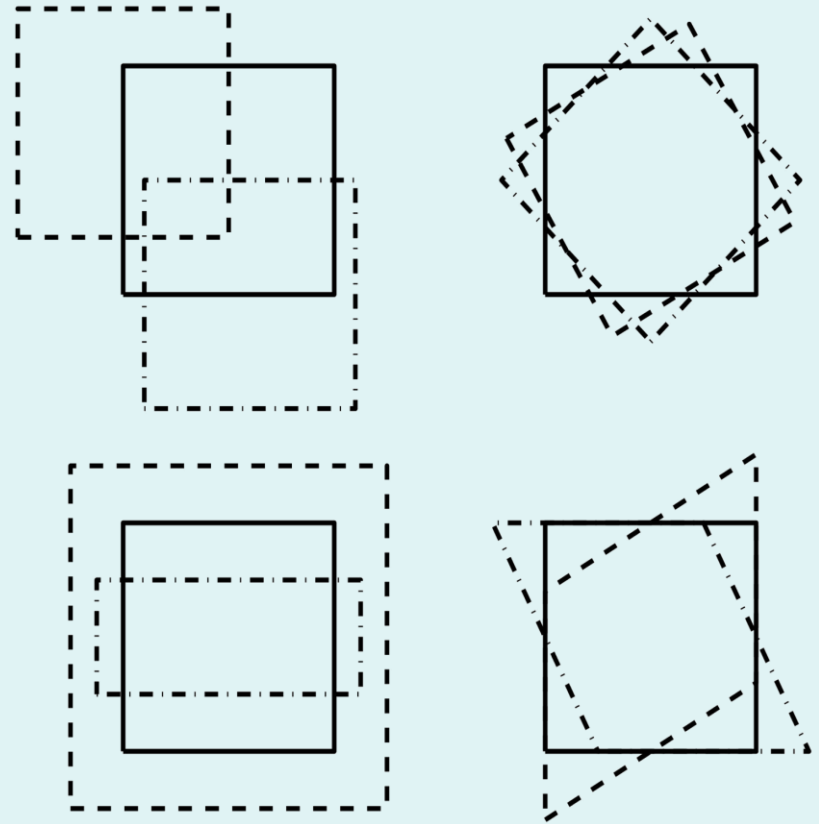

Same for  $h_y$

# 2D Affine transform

- Operations can be represented by:

$$x_1 = m_{11}x_0 + m_{12}y_0 + m_{13}$$

$$y_1 = m_{21}x_0 + m_{22}y_0 + m_{23}$$

- ...or as matrices:

$$\mathbf{p}_1 = \mathbf{M} \mathbf{p}_0 \quad \begin{bmatrix} x_1 \\ y_1 \\ 1 \end{bmatrix} = \begin{bmatrix} m_{11} & m_{12} & m_{13} \\ m_{21} & m_{22} & m_{23} \\ 0 & 0 & 1 \end{bmatrix} \times \begin{bmatrix} x_0 \\ y_0 \\ 1 \end{bmatrix}$$

- Parallel lines remain parallel

Rigid-body transformations are a subset of “affine transformation”

# 3D Affine transform

- Operations can be represented by:

$$x_1 = m_{11}x_0 + m_{12}y_0 + m_{13}z_0 + m_{14}$$

$$y_1 = m_{21}x_0 + m_{22}y_0 + m_{23}z_0 + m_{24}$$

$$z_1 = m_{31}x_0 + m_{32}y_0 + m_{33}z_0 + m_{34}$$

- Or as matrices:

$$\mathbf{p}_1 = \mathbf{M} \mathbf{p}_0$$

$$\begin{bmatrix} x_1 \\ y_1 \\ z_1 \\ 1 \end{bmatrix} = \begin{bmatrix} m_{11} & m_{12} & m_{13} & m_{14} \\ m_{21} & m_{22} & m_{23} & m_{24} \\ m_{31} & m_{32} & m_{33} & m_{34} \\ 0 & 0 & 0 & 1 \end{bmatrix} \times \begin{bmatrix} x_0 \\ y_0 \\ z_0 \\ 1 \end{bmatrix}$$

- Parallel lines remain parallel

Rigid-body transformations are a subset of “affine transformation”

# Rigid-body transformations

---

- Assume that brain of the same subject doesn't change shape or size in the scanner.
  - Head can move, but remains the same shape and size.
  - Some exceptions:
    - Image distortions.
    - Brain slops about slightly because of gravity.
    - Brain growth or atrophy over time.
- If the subject's head moves, we need to "match" the images.
  - Do this by image registration.



# 3D Rigid-body Transform

- A 3D rigid body transform is an affine transform defined by:
  - 3 translations - in X, Y & Z directions
  - 3 rotations - about X, Y & Z axes

$$R = \begin{pmatrix} 1 & 0 & 0 & X_{\text{trans}} \\ 0 & 1 & 0 & Y_{\text{trans}} \\ 0 & 0 & 1 & Z_{\text{trans}} \\ 0 & 0 & 0 & 1 \end{pmatrix} \times \begin{pmatrix} 1 & 0 & 0 & 0 \\ 0 & \cos f & \sin f & 0 \\ 0 & -\sin f & \cos f & 0 \\ 0 & 0 & 0 & 1 \end{pmatrix} \times \begin{pmatrix} \cos q & 0 & \sin q & 0 \\ 0 & 1 & 0 & 0 \\ -\sin q & 0 & \cos q & 0 \\ 0 & 0 & 0 & 1 \end{pmatrix} \times \begin{pmatrix} \cos \Omega & \sin \Omega & 0 & 0 \\ -\sin \Omega & \cos \Omega & 0 & 0 \\ 0 & 0 & 1 & 0 \\ 0 & 0 & 0 & 1 \end{pmatrix}$$

Translations                      Pitch about x axis                      Roll about y axis                      Yaw about z axis

- The order of the operations matters!

# Voxel-to-world transformation

---

“Voxel-to-world transforms” =

*Affine transform* **M** associated with each image such that

- Maps from voxels ( $\mathbf{x}=[1\dots N_x]$ ,  $\mathbf{y}=[1\dots N_y]$ ,  $\mathbf{z}=[1\dots N_z]$ ) to some world co-ordinate system. e.g.,
  - Scanner co-ordinates - images from DICOM toolbox
  - T&T/MNI coordinates - spatially normalised
- World coordinates are (usually) in millimetres!

# Image resampling

A continuous function is represented by a linear combination of basis functions

## 1D interpolation

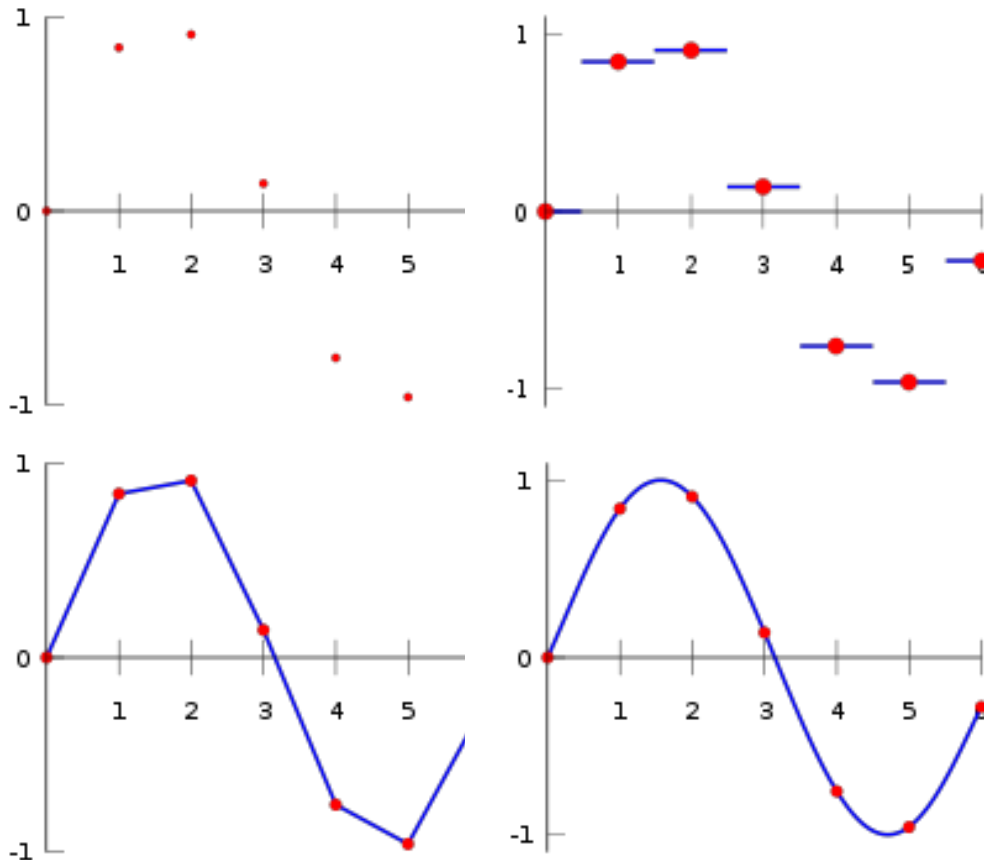

2D  
interpolation  
kernels

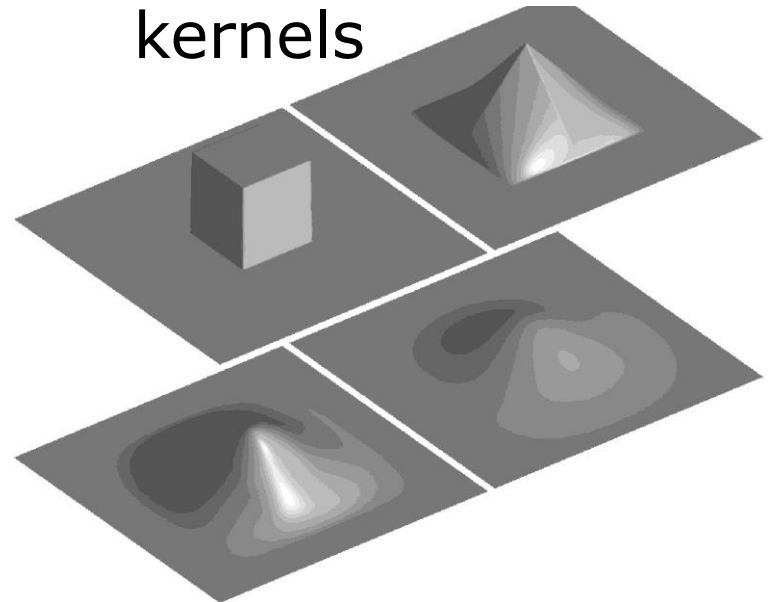

# Image resampling

- Nearest neighbour
  - Take the value of the closest voxel
- Tri-linear
  - Just a weighted average of the neighbouring voxels
  - $f_5 = f_1 x_2 + f_2 x_1$
  - $f_6 = f_3 x_2 + f_4 x_1$
  - $f_7 = f_5 y_2 + f_6 y_1$

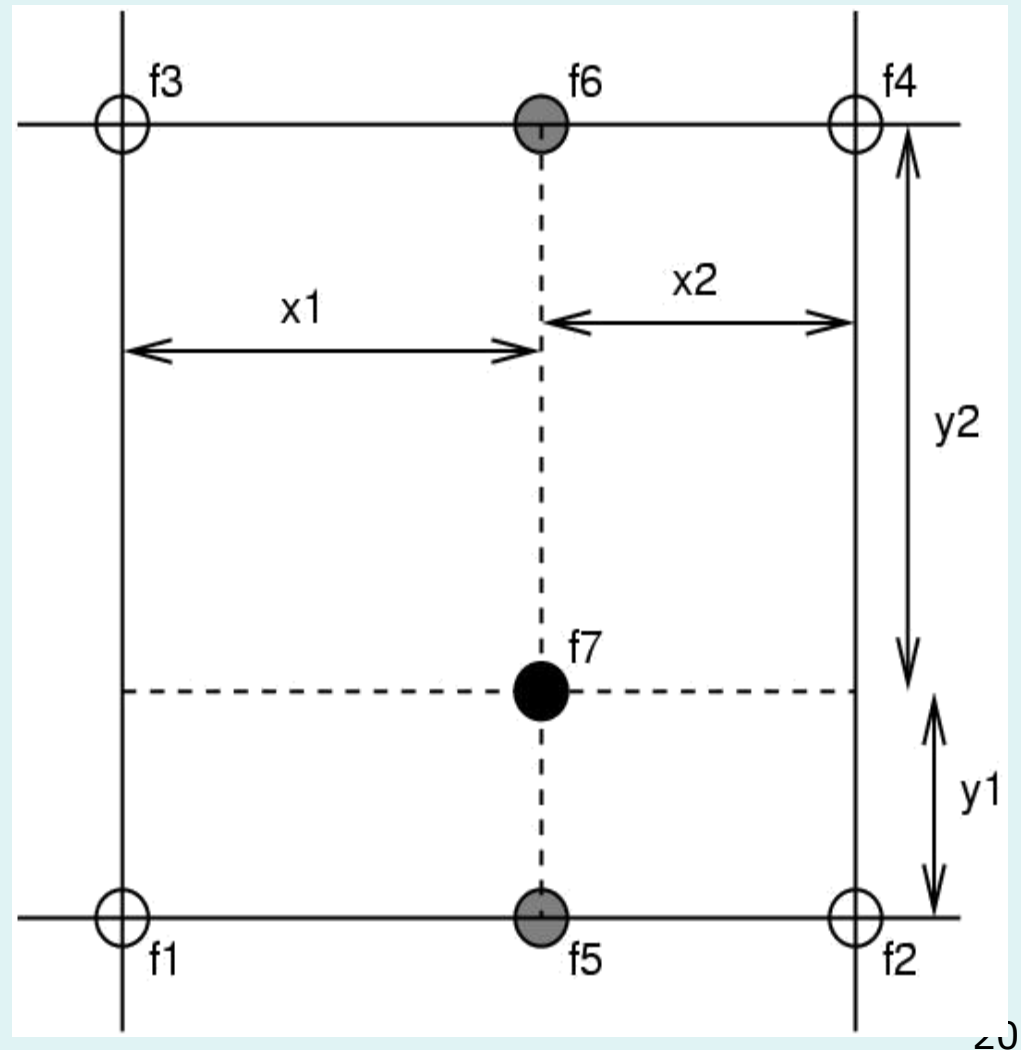

# Image resampling, example 1

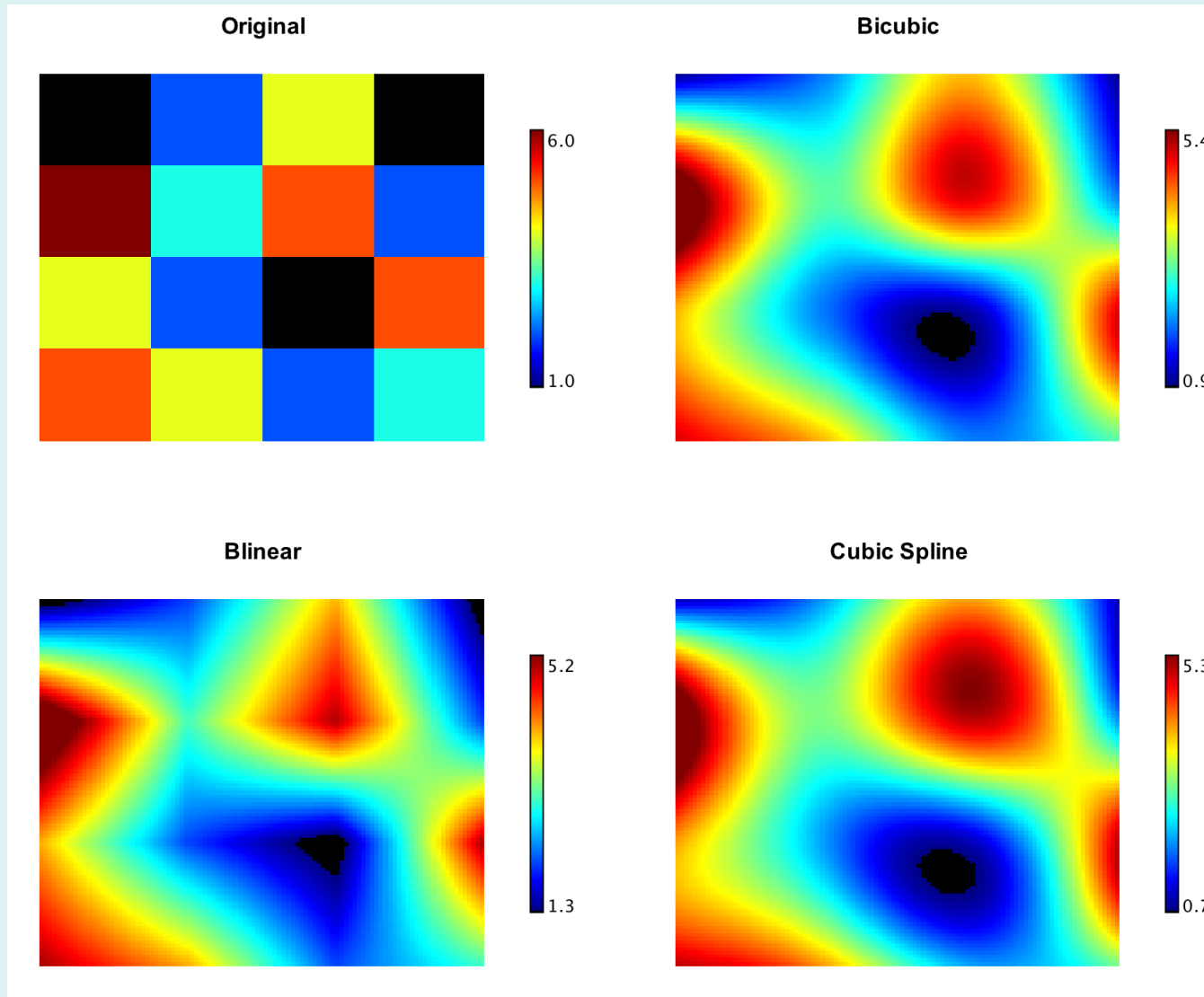

# Image resampling, example 2

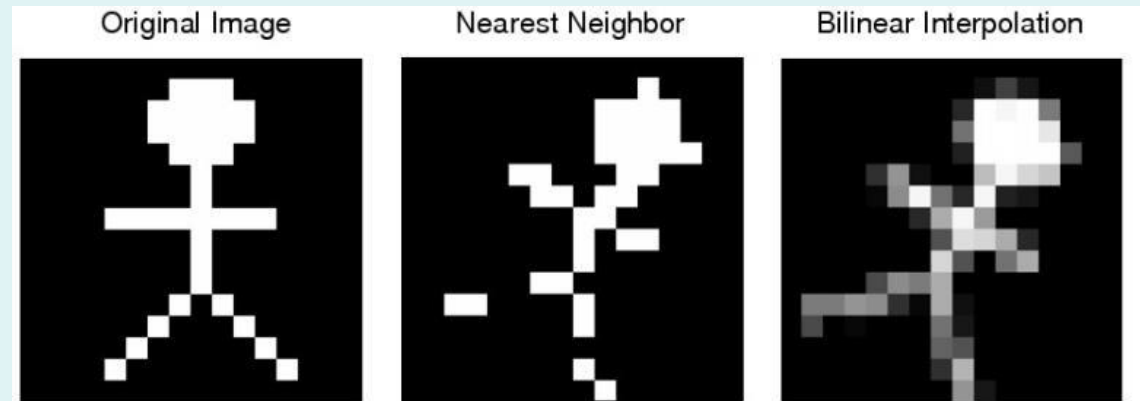
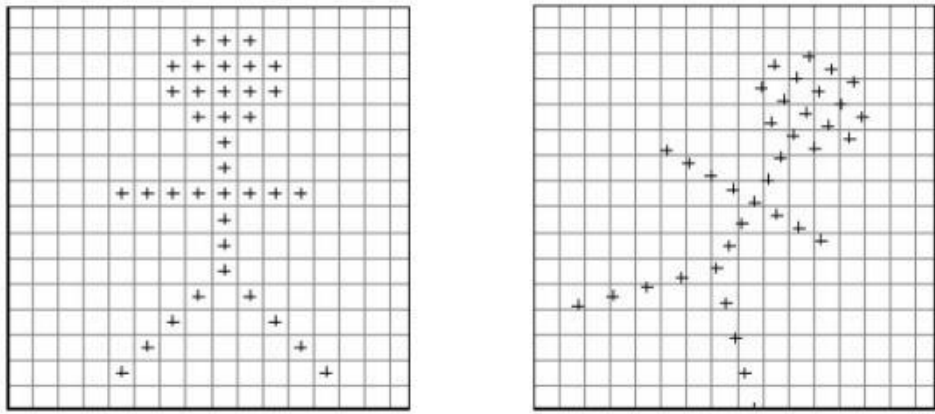

Binary (or index) image

→ need to preserve property

→ no need for smooth interpolation but...

# Various registration problems

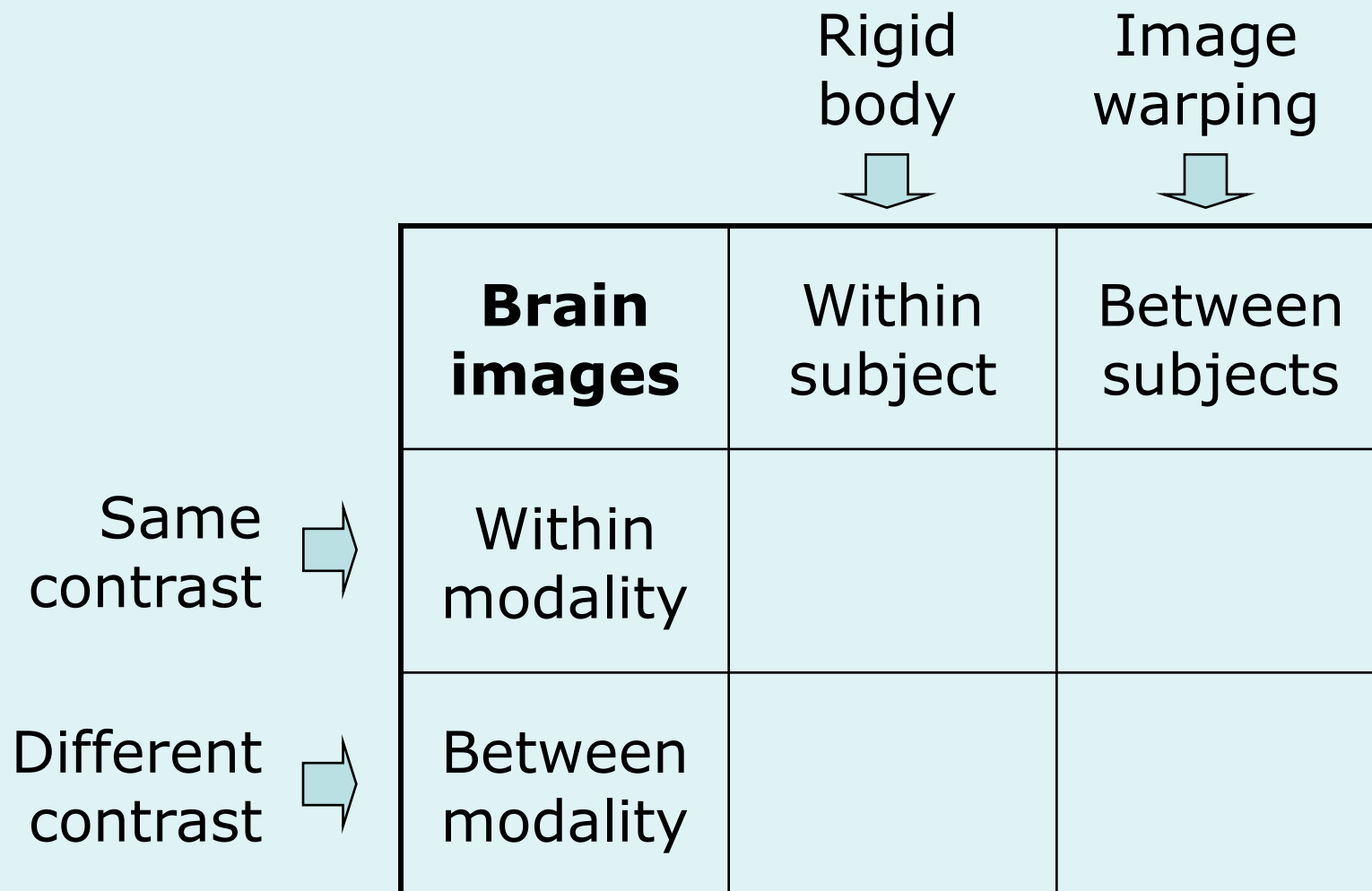

# Pre-processing overview

fMRI time-series

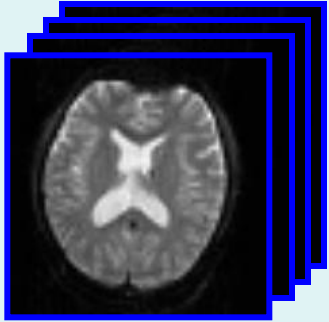

Motion (& distortion)  
Correction

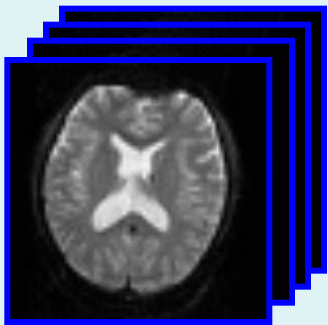

Anatomical MRI

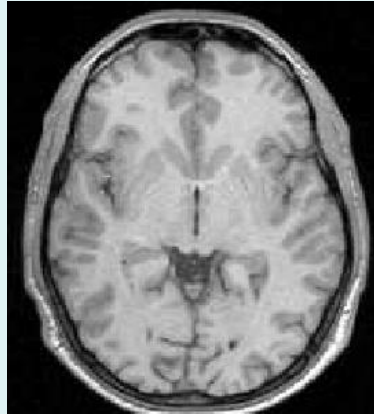

Coregister

$$\begin{pmatrix} m_{11} & m_{12} & m_{13} & m_{14} \\ m_{21} & m_{22} & m_{23} & m_{24} \\ m_{31} & m_{32} & m_{33} & m_{34} \\ \mathbf{0} & \mathbf{0} & \mathbf{0} & \mathbf{1} \end{pmatrix}$$



# Various registration problems

		Rigid body	Image warping
<b>Brain images</b>		Within subject	Between subjects
Same contrast	Within modality	X	
Different contrast	Between modality		

# Content

---

- **Preliminaries**

- **Within-subject**

- **Realignment**

- **Minimising mean-squared difference / Residual artifacts**

- **EPI Distortion correction**

- **FieldMap Toolbox / Movement by distortion interaction**

- **Coregistration**

- **Maximising mutual information**

- **Between-subject**

- **Smoothing**

- **Conclusion**

# Mean-squared difference

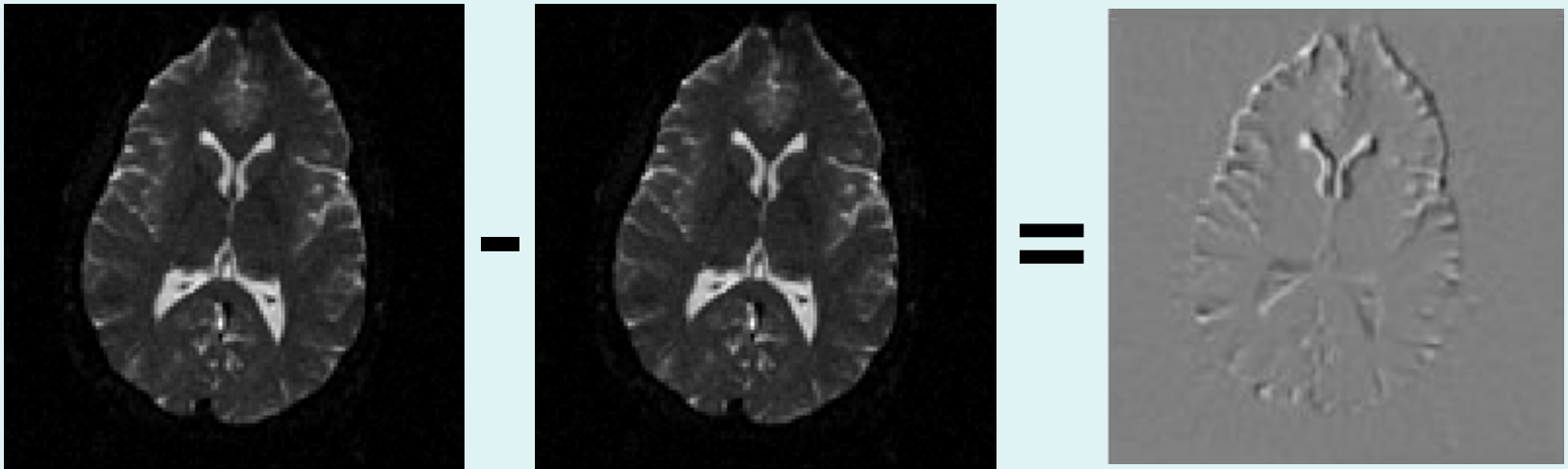

- Minimising mean-squared difference works for intra-modal registration

$$c(I, J) = \sum_{n=1}^N (I_n - J_n)^2$$

- Simple relationship between intensities in one image, versus those in the other  
(Assumes normally distributed differences, i.e. residuals)

# Within-subject registration

- Realign images  $I$  (fixed) and  $J$  (moving):
- Criteria to optimize:

$$\rightarrow c(I, J) = \sum_{n=1}^N (I_n - J_n)^2$$

- $c(I, J)$  depends on  $J$ 's orientation, which depends on  $R$ 's 6 parameters
  - Optimize  $c(I, J)$  according to those 6 parameters !

$$R = \begin{pmatrix} 1 & 0 & 0 & X_{\text{trans}} \\ 0 & 1 & 0 & Y_{\text{trans}} \\ 0 & 0 & 1 & Z_{\text{trans}} \\ 0 & 0 & 0 & 1 \end{pmatrix} \times \begin{pmatrix} 1 & 0 & 0 & 0 \\ 0 & \cos f & \sin f & 0 \\ 0 & -\sin f & \cos f & 0 \\ 0 & 0 & 0 & 1 \end{pmatrix} \times \begin{pmatrix} \cos q & 0 & \sin q & 0 \\ 0 & 1 & 0 & 0 \\ -\sin q & 0 & \cos q & 0 \\ 0 & 0 & 0 & 1 \end{pmatrix} \times \begin{pmatrix} \cos \Omega & \sin \Omega & 0 & 0 \\ -\sin \Omega & \cos \Omega & 0 & 0 \\ 0 & 0 & 1 & 0 \\ 0 & 0 & 0 & 1 \end{pmatrix}$$

Objective function

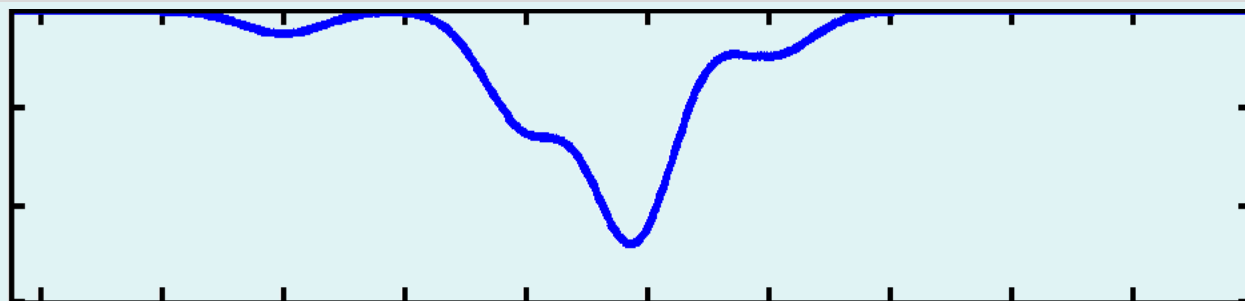

Value of parameter

# Motion estimates

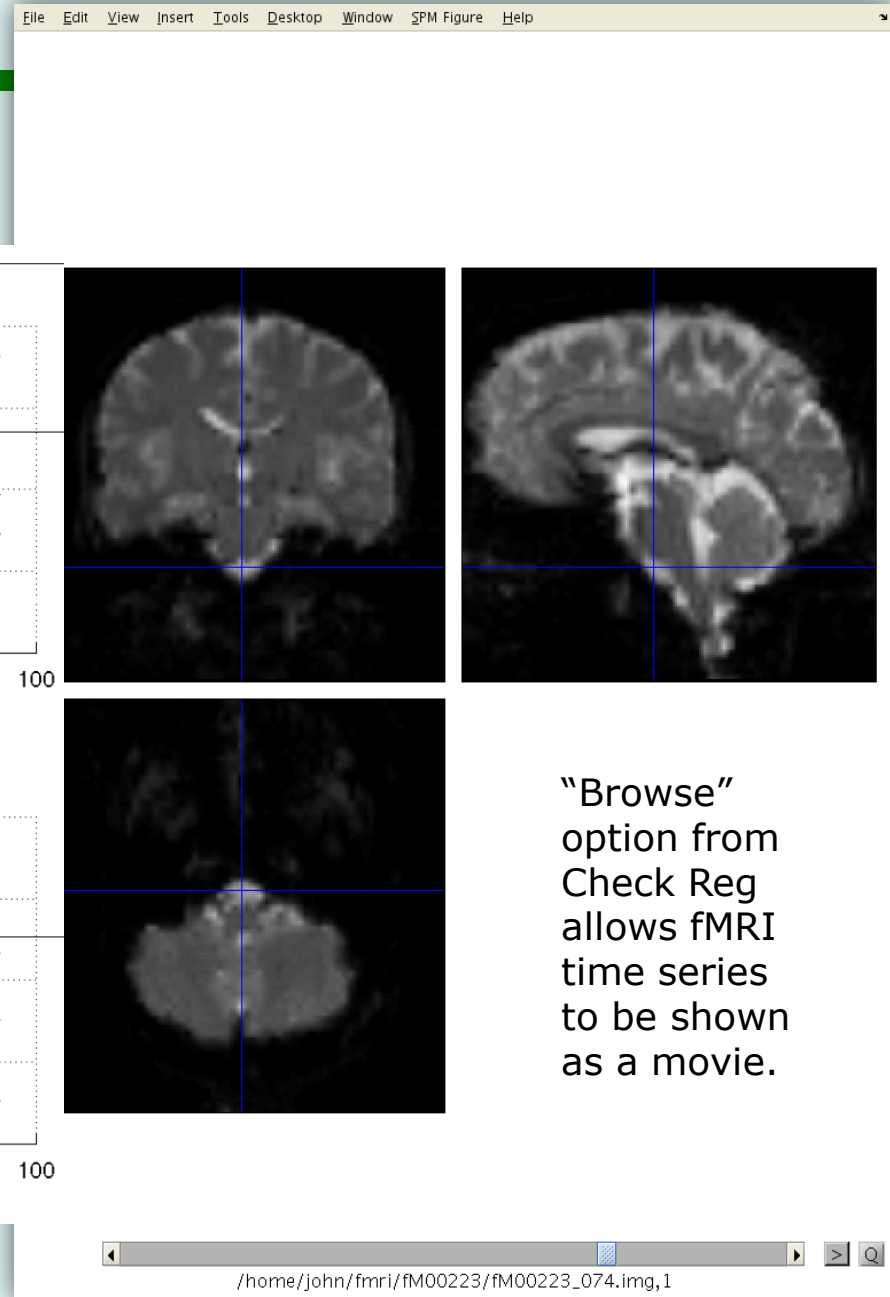

translation

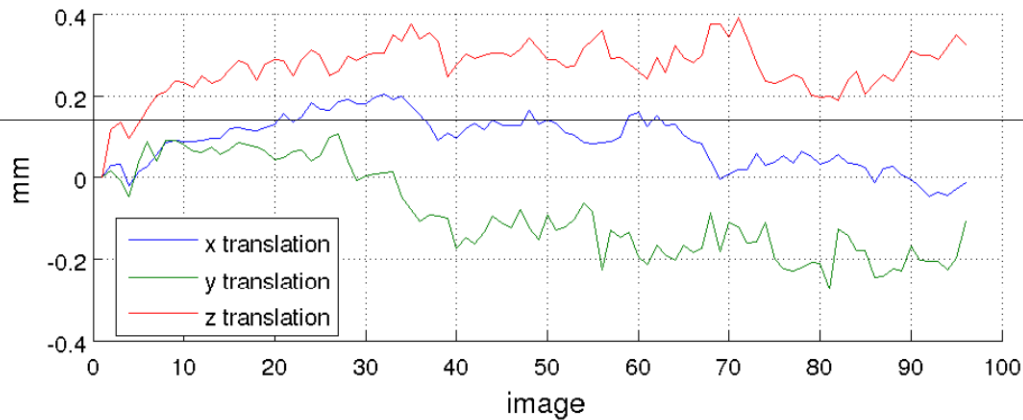

rotation

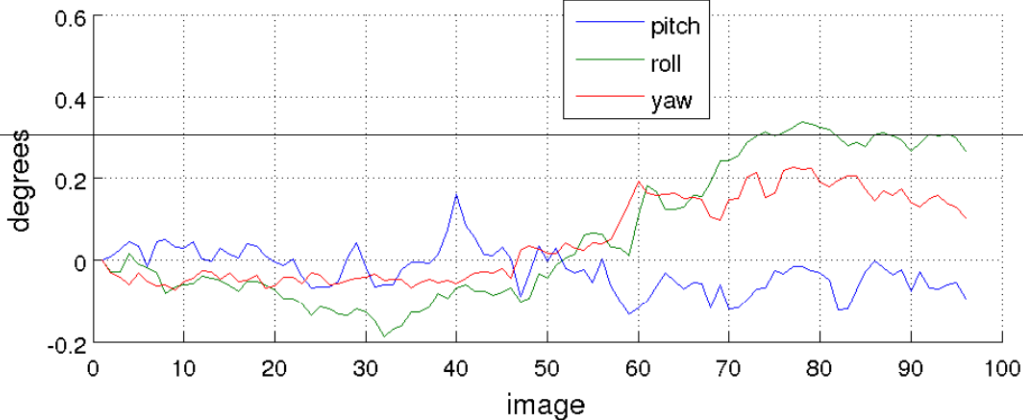

“Browse” option from Check Reg allows fMRI time series to be shown as a movie.

# Residual errors from aligned fMRI

---

- Re-sampling can introduce interpolation errors
    - tri-linear interpolation  $\sim$  smoothing
  - Gaps between slices can cause aliasing artefacts
  - Slices are not acquired simultaneously
    - rapid movements not accounted for by rigid body model
  - Image artefacts may not move according to a rigid body model
    - image distortion, image dropout, Nyquist ghost
  - BOLD signal changes influence the estimated motion.
- ➔ Functions of the estimated motion parameters can be modelled as confounds in subsequent analyses

# EPI distortion

- Magnetic susceptibility differs among tissues.
- Greatest difference is between air and tissue.
- Subject disrupts  $B_0$  field, rendering it inhomogeneous
- Distortions in phase-encode direction

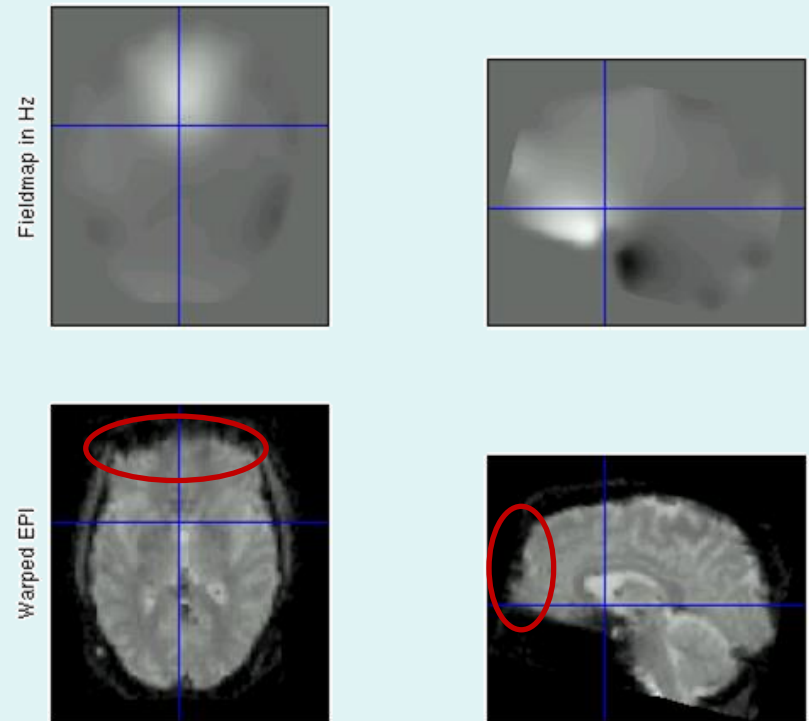

# FieldMap toolbox

- Computes a voxel-displacement map (VDM) from “fieldmap” scans.
- Used to correct distortions in EPI.

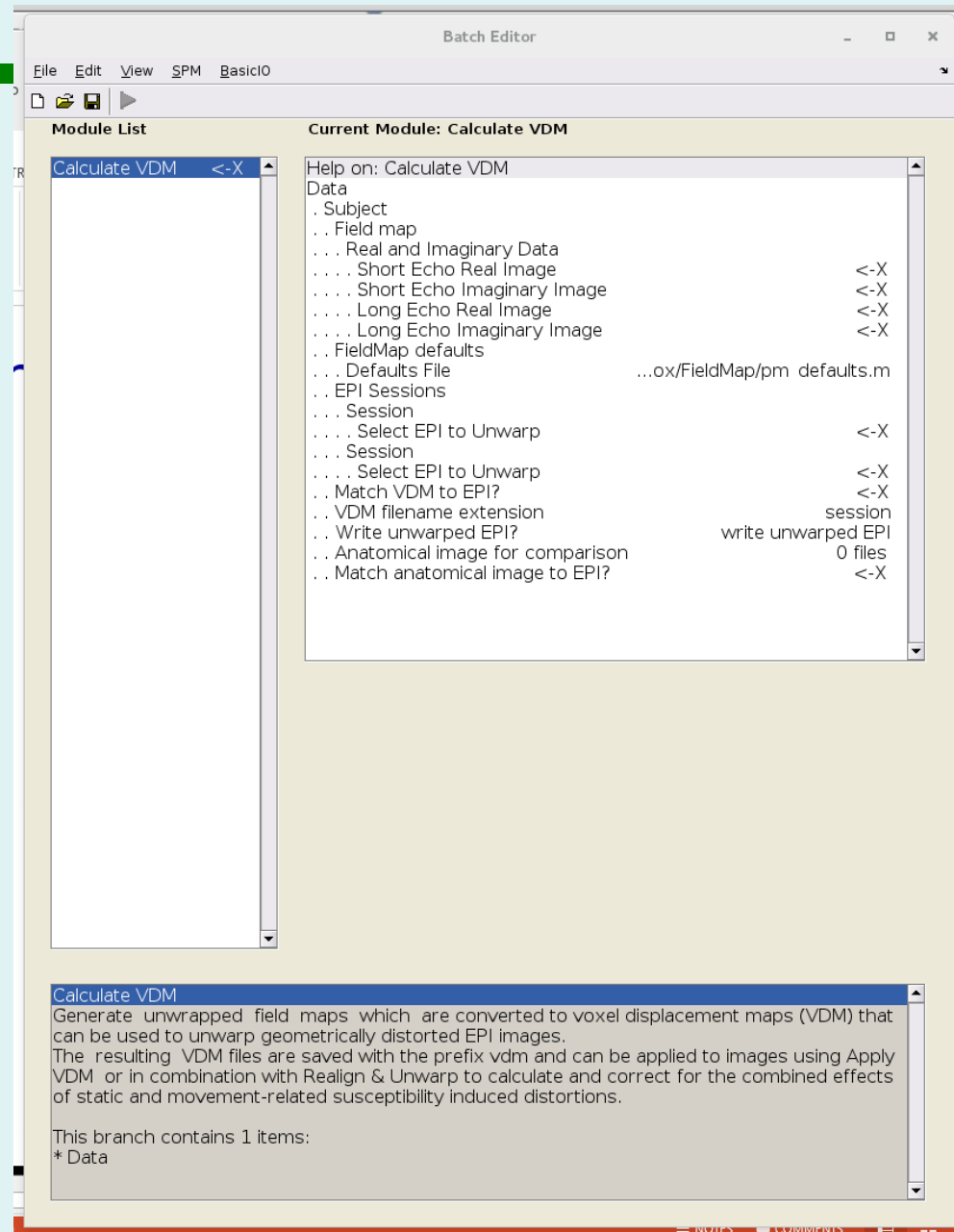



# Phase unwrapping

- Phase of complex data used.
  - $-\pi < \text{phase} < \pi$
  - Phase-unwrapping needed.
  - Phase is poorly defined when magnitude is small relative to noise
- ➔ Part that is most likely to go wrong.

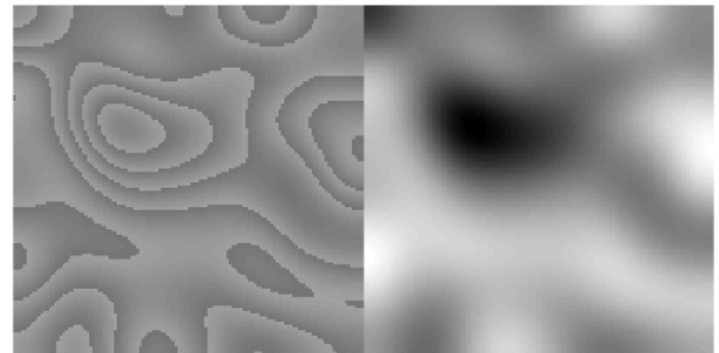
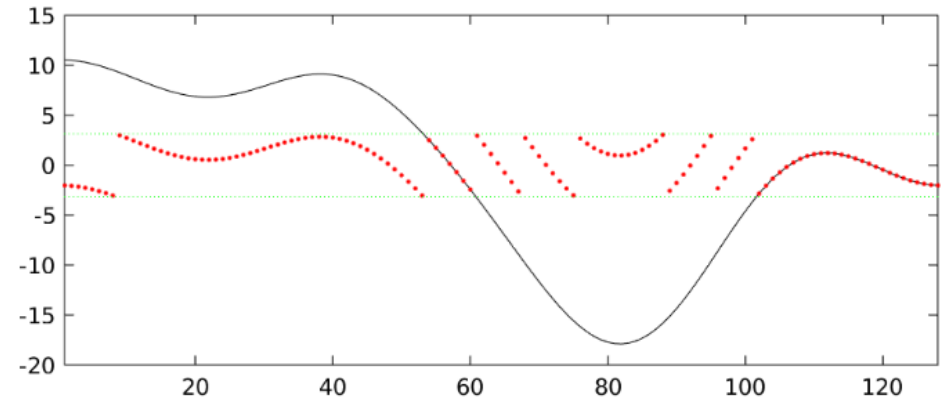
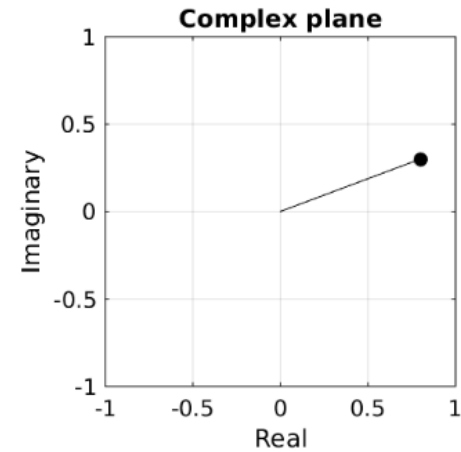

# Movement-by-distortion interaction

Original position

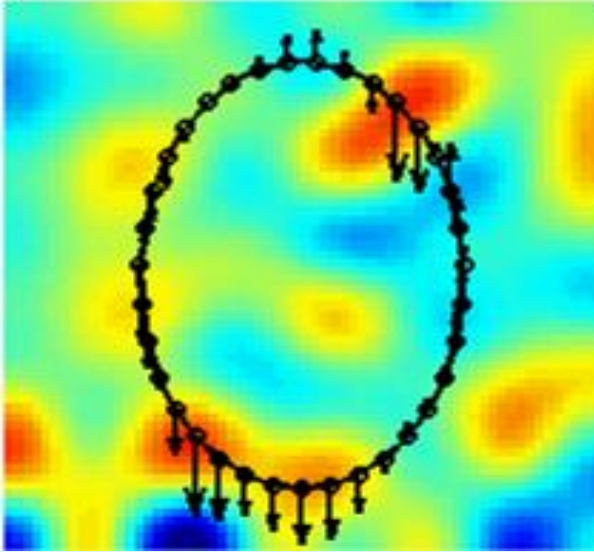

After rotation

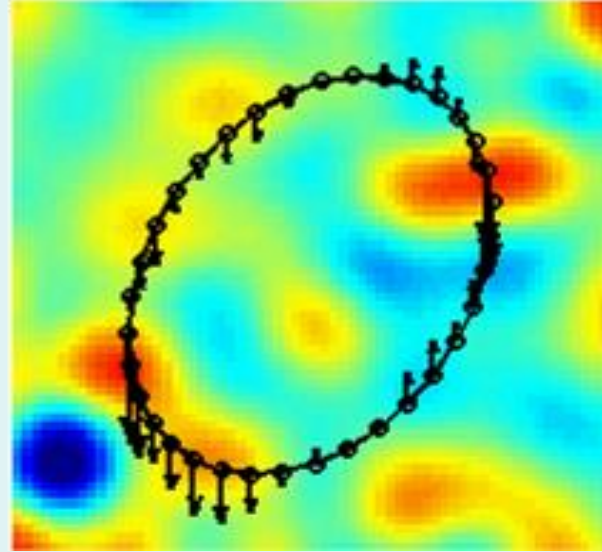

Original position

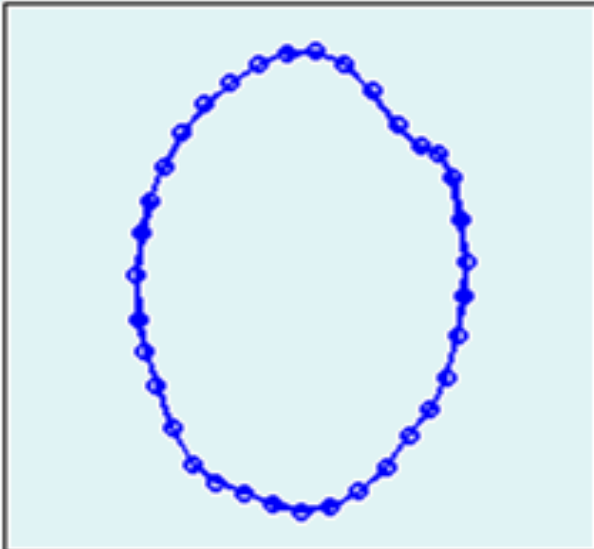

After rotation

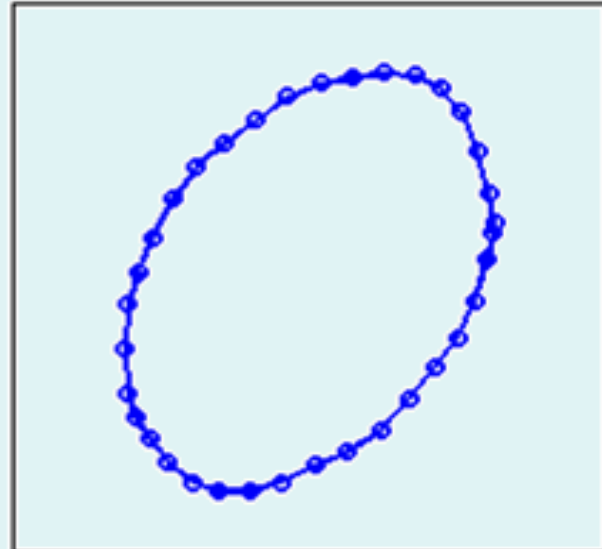

# “Realign & Unwarp”

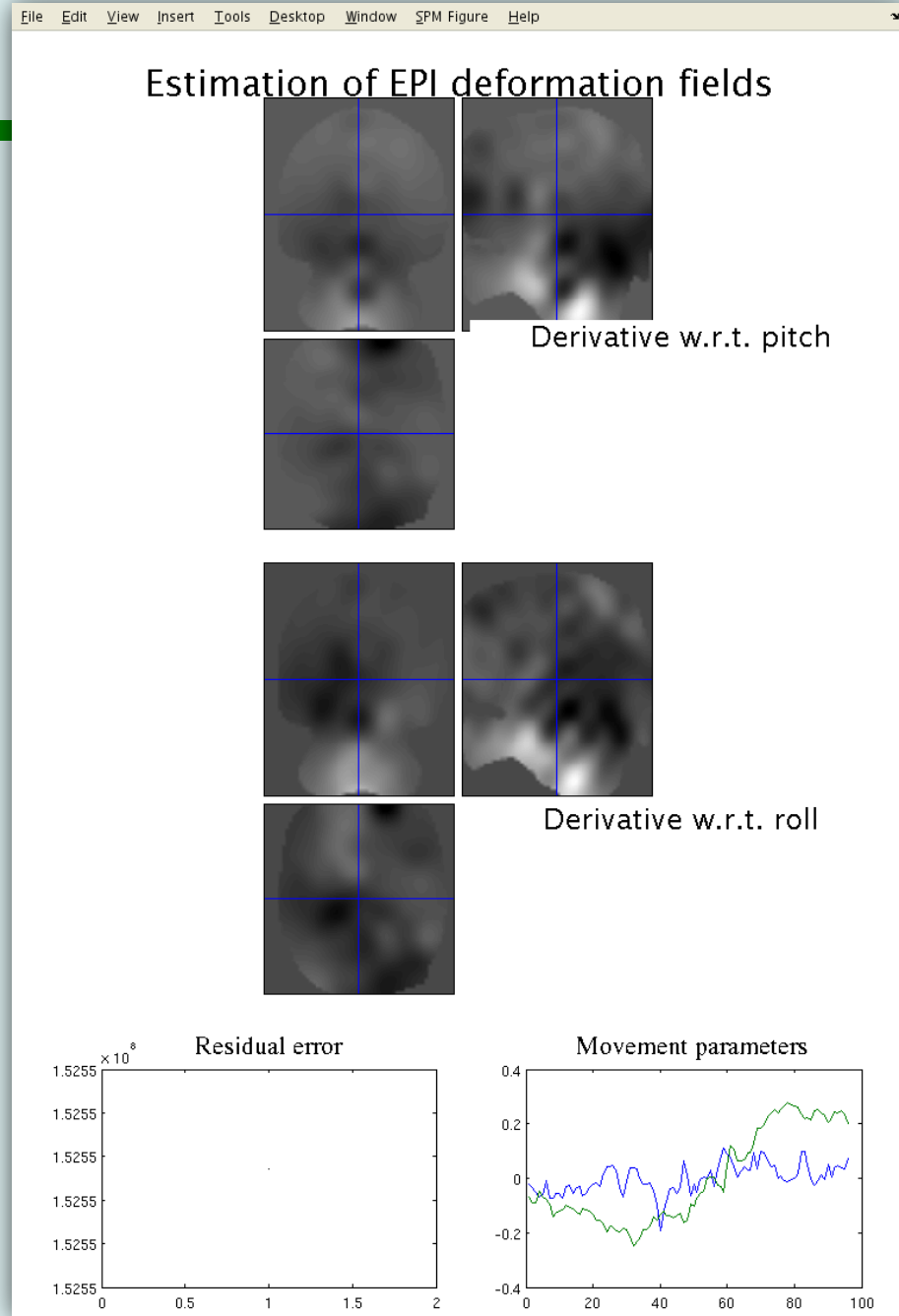
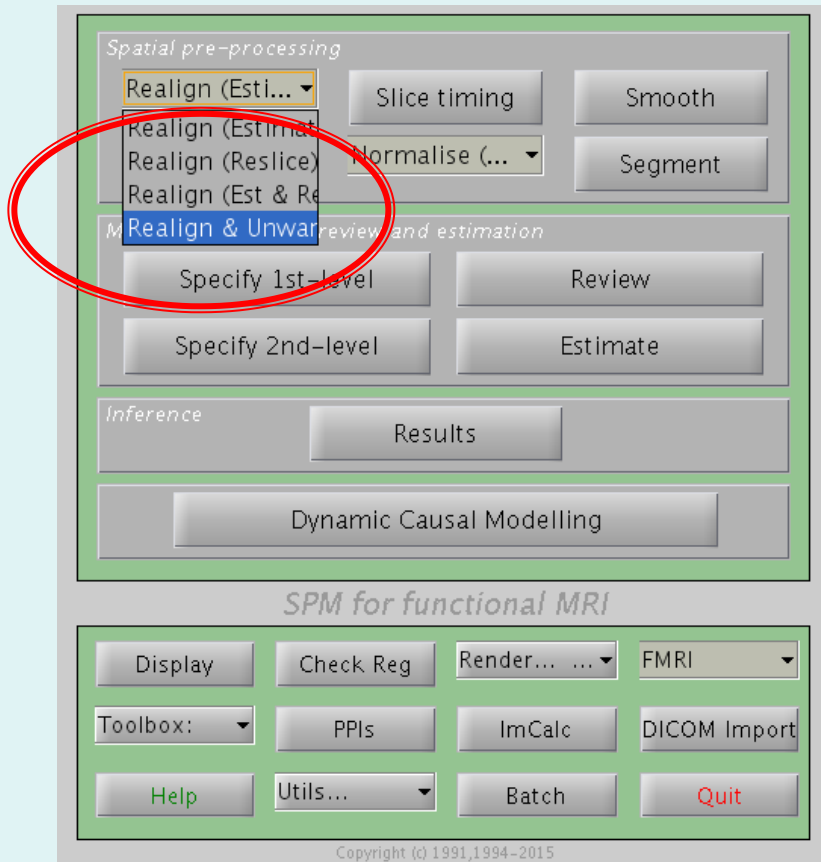

# Correcting for distortion changes

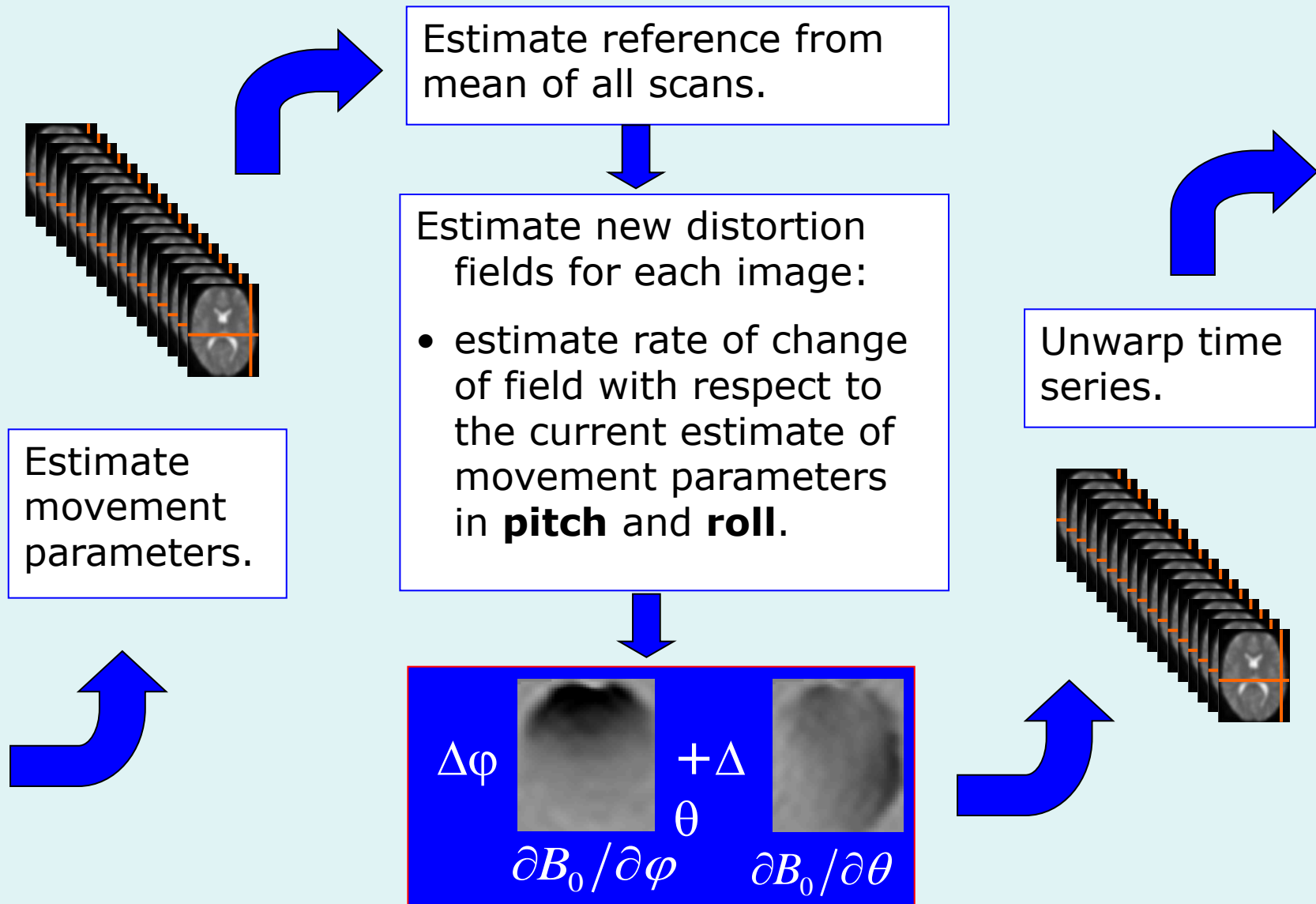

# Various registration problems

		Rigid body	Image warping
<b>Brain images</b>		Within subject	Between subjects
Same contrast	Within modality	<b>X</b>	
Different contrast	Between modality	X	

# “Coregistration”

---

- Inter-modal registration.
- Match images from same subject but different modalities:
  - anatomical localisation of single subject activations
  - achieve more precise spatial normalisation of functional image using anatomical image.

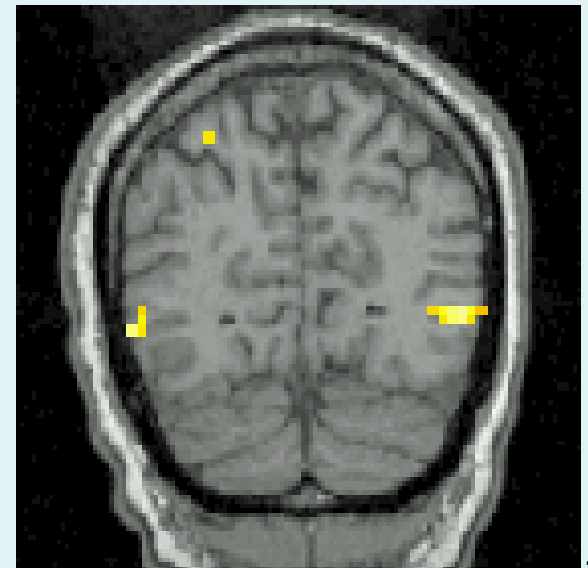
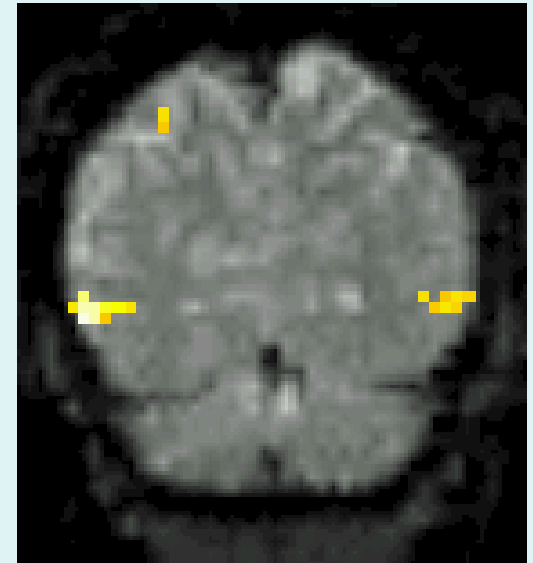

# Joint histogram & Mutual information

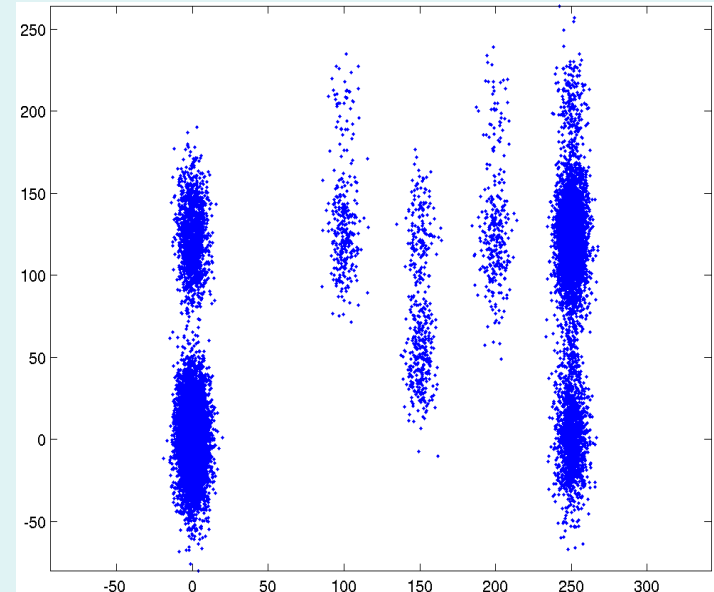
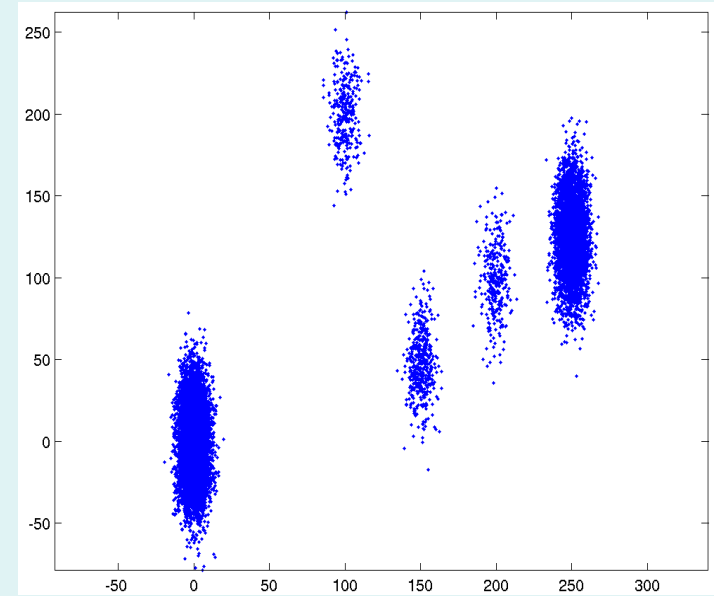
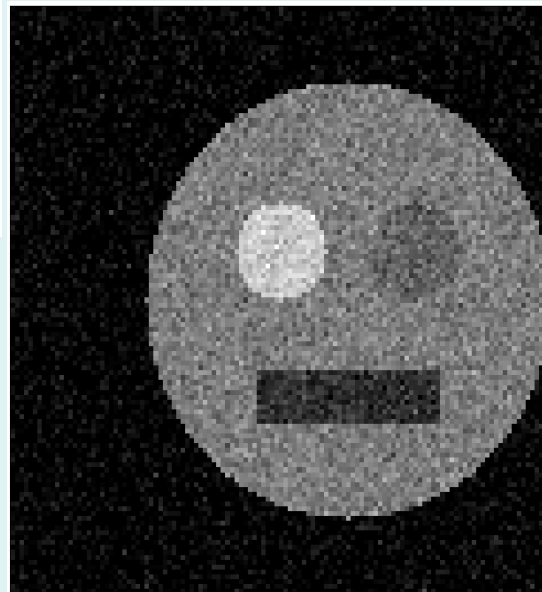
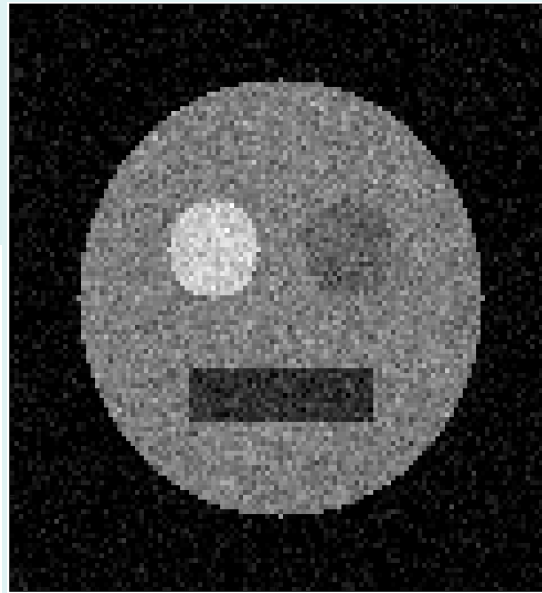
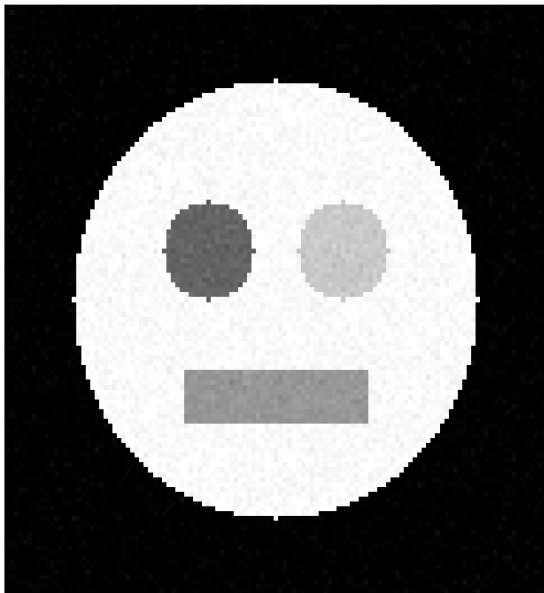

# Mutual Information, real case

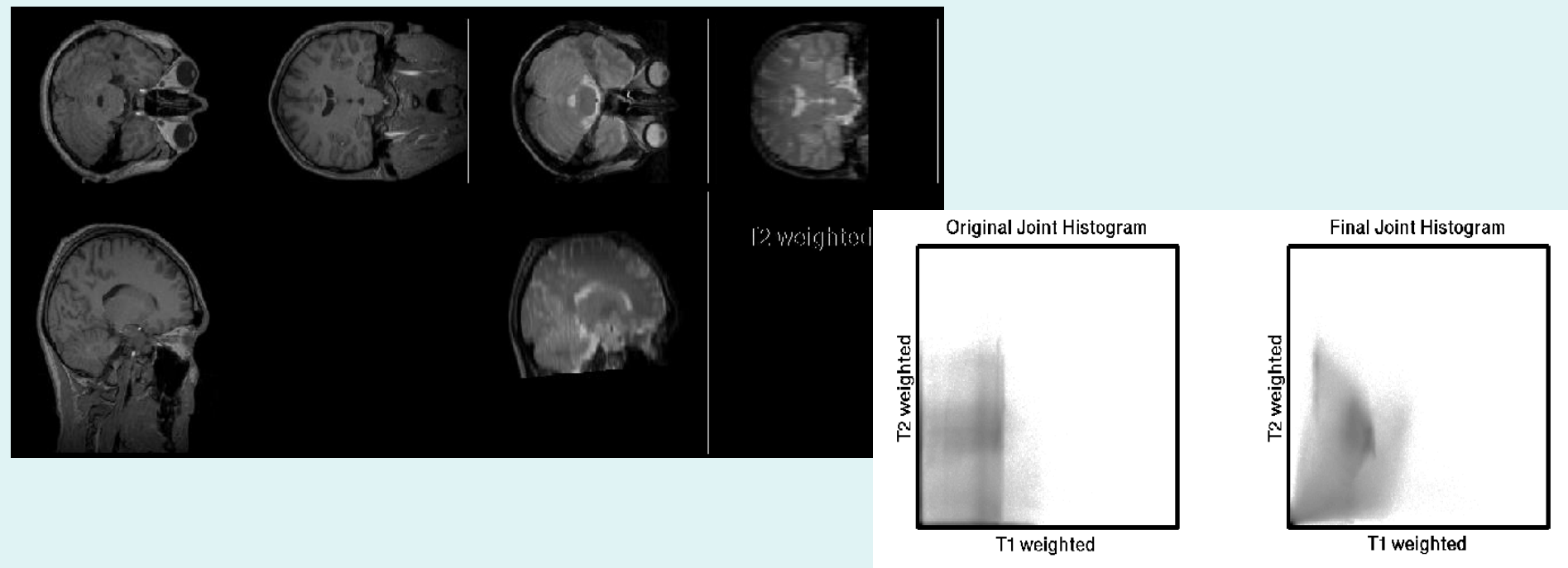

- Used for between-modality registration
- Derived from joint histograms
- $MI = \int_{ab} P(a,b) \log_2 [P(a,b) / (P(a) P(b))]$ 
  - Related to entropy:  $MI = -H(a,b) + H(a) + H(b)$   
Where  $H(a) = -\int_a P(a) \log_2 P(a)$  and  $H(a,b) = -\int_{ab} P(a,b) \log_2 P(a,b)$



# Within-subject registration

- Realign images  $I$  (fixed) and  $J$  (moving):
- Criteria to optimize:

$$\rightarrow c(I, J) = MI(I, J)$$

- $c(I, J)$  depends on  $J$ 's orientation, which depends on  $R$ 's 6 parameters
  - Optimize  $c(I, J)$  according to those 6 parameters !

$$R = \begin{pmatrix} 1 & 0 & 0 & X_{\text{trans}} \\ 0 & 1 & 0 & Y_{\text{trans}} \\ 0 & 0 & 1 & Z_{\text{trans}} \\ 0 & 0 & 0 & 1 \end{pmatrix} \times \begin{pmatrix} 1 & 0 & 0 & 0 \\ 0 & \cos f & \sin f & 0 \\ 0 & -\sin f & \cos f & 0 \\ 0 & 0 & 0 & 1 \end{pmatrix} \times \begin{pmatrix} \cos q & 0 & \sin q & 0 \\ 0 & 1 & 0 & 0 \\ -\sin q & 0 & \cos q & 0 \\ 0 & 0 & 0 & 1 \end{pmatrix} \times \begin{pmatrix} \cos \Omega & \sin \Omega & 0 & 0 \\ -\sin \Omega & \cos \Omega & 0 & 0 \\ 0 & 0 & 1 & 0 \\ 0 & 0 & 0 & 1 \end{pmatrix}$$

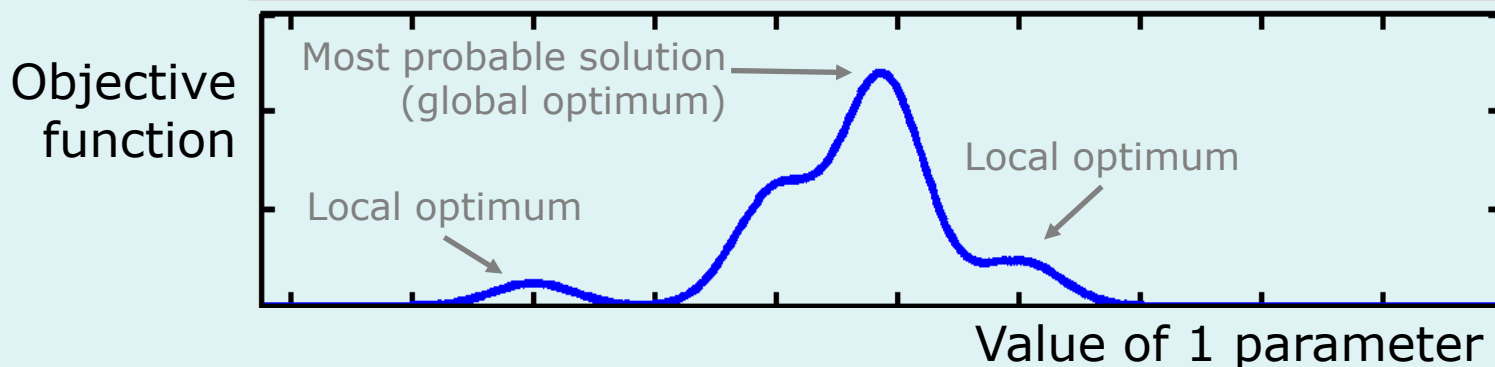

# “CheckReg” to assess alignment

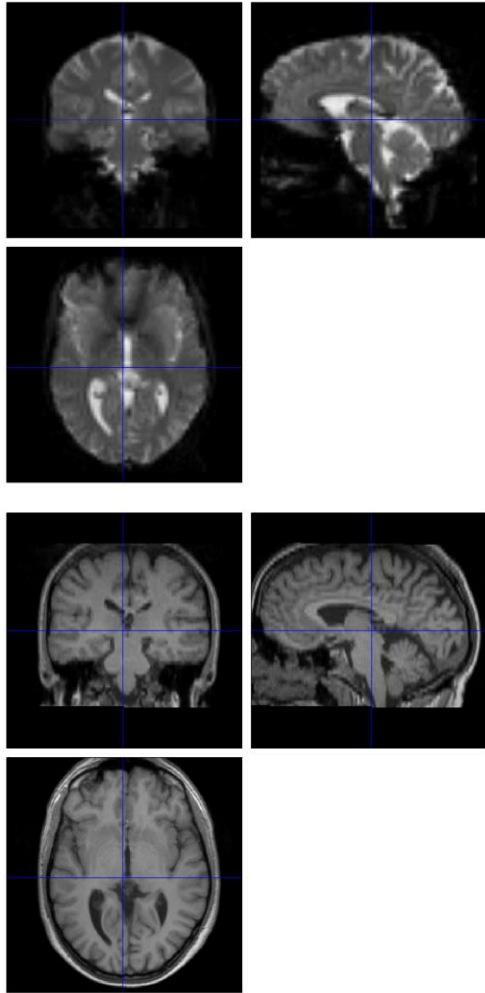

CheckReg allows contours from one image to be shown superimposed on another

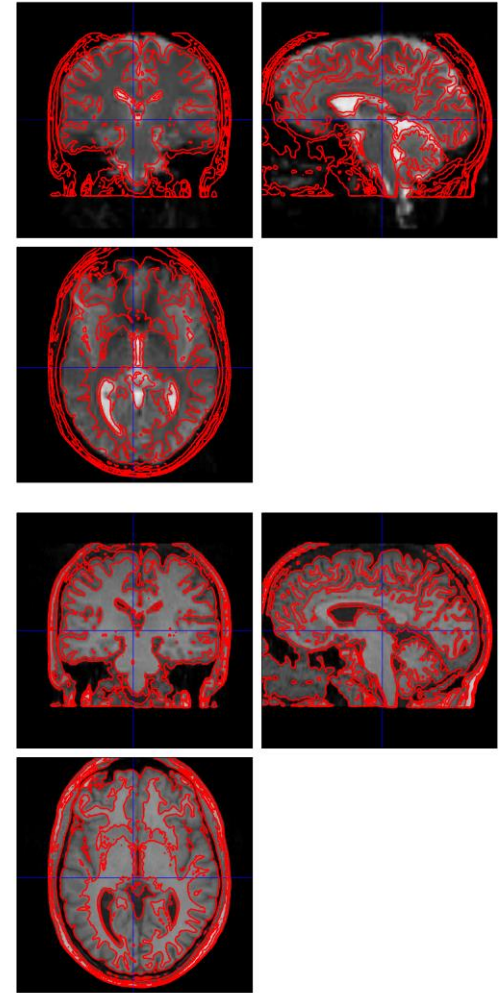

# EPI dropout and distortion

---

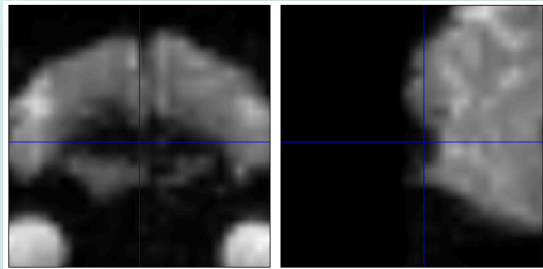

EPI

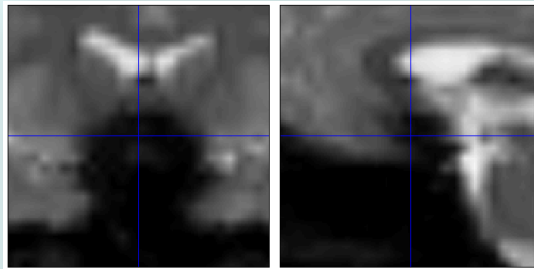
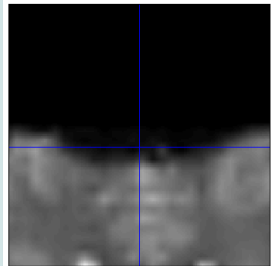

EPI

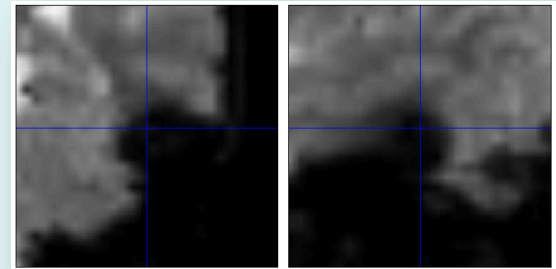
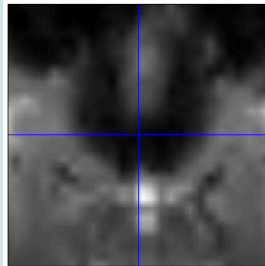

EPI

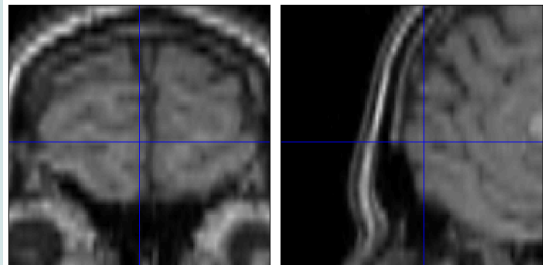
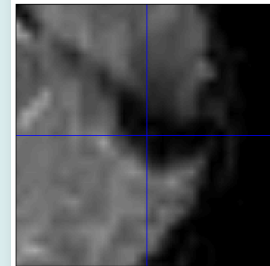

structural

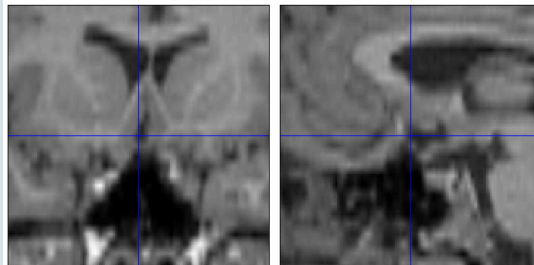
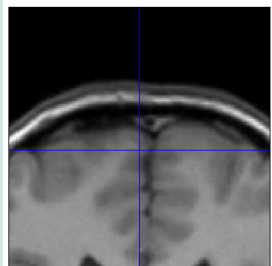

structural

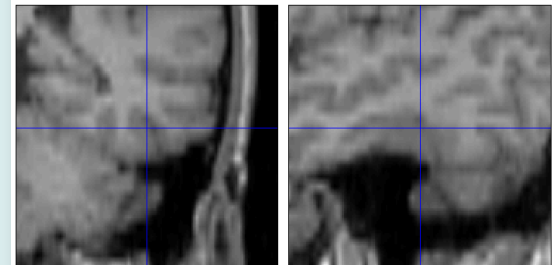
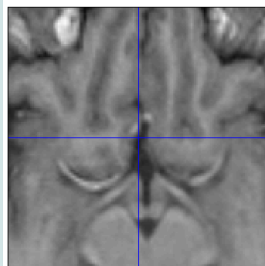

structural

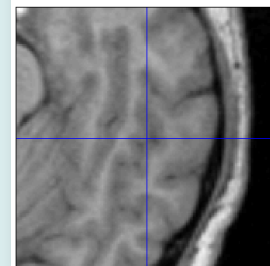

# Voxel-to-world transformation

---

“Voxel-to-world transforms” =

*Affine transform* **M** associated with each image such that

- Maps from voxels ( $\mathbf{x}=[1\dots N_x]$ ,  $\mathbf{y}=[1\dots N_y]$ ,  $\mathbf{z}=[1\dots N_z]$ ) to some world co-ordinate system. e.g.,
  - Scanner co-ordinates - images from DICOM toolbox
  - T&T/MNI coordinates - spatially normalised
- World coordinates are (usually) in millimetres!

# Voxel-to-world transformation

- Registering image B (source) to image A (target) will update B's voxel-to-world mapping.

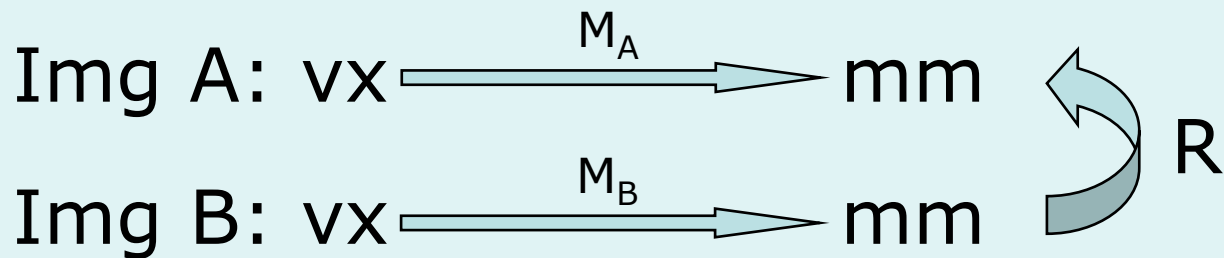

- Mapping from voxels in B to voxels in A is by combining  $M_B$  and R:  $M_B^* = M_B R$ 
  - B-to-world using  $M_B^*$ , then world-to-A using  $M_A^{-1} \Rightarrow M_B^* M_A^{-1}$

# Various registration problems

		Rigid body ↓	Image warping ↓
<b>Brain images</b>		Within subject	Between subjects
Same contrast →	Within modality	<b>X</b>	X
Different contrast →	Between modality	<b>X</b>	

# Content

---

- **Preliminaries**
- **Within-subject**
- **Between-subject**
  - Unified segmentation for spatial normalisation**
    - **Gaussian mixture model**
    - **Intensity non-uniformity correction**
    - **Deformed tissue probability maps**
- **Smoothing**
- **Conclusion**

# Pre-processing overview

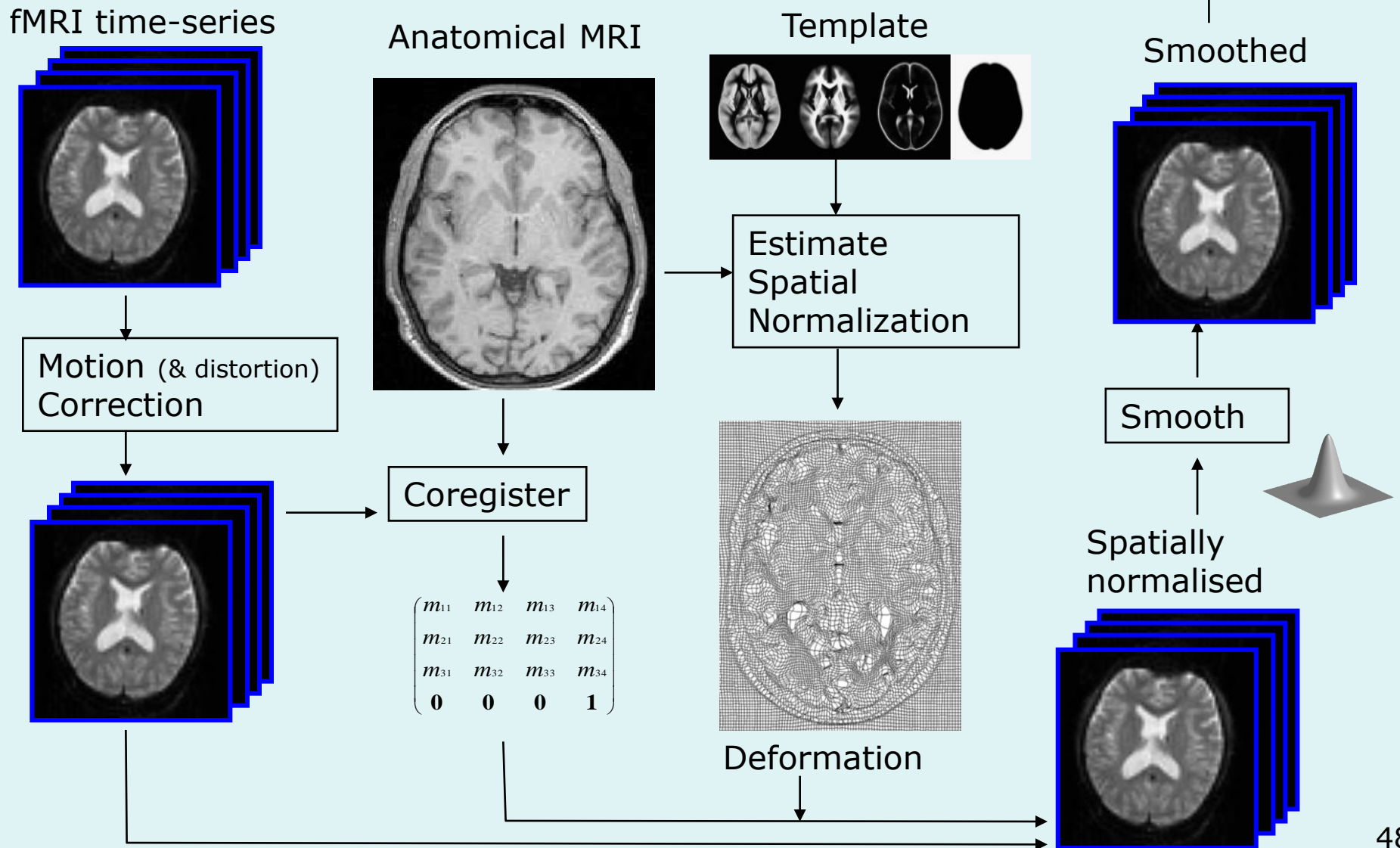



# Between subjects

---

Brains of different subjects vary in *shape* and *size*.

# Between subjects

---

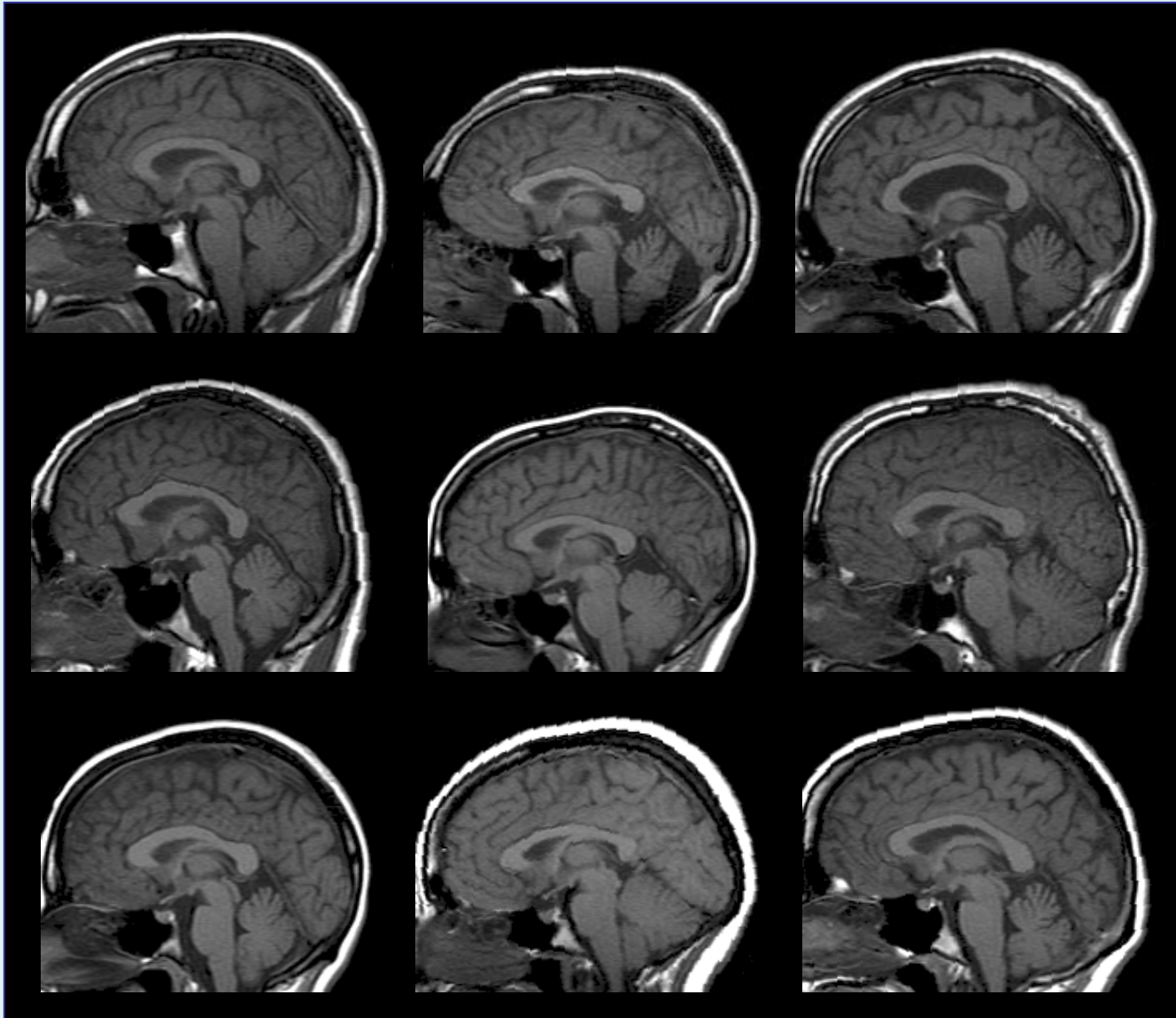

# Between subjects

---

Brains of different subjects vary in *shape* and *size*.

- Need to bring them all into a common anatomical space.
  - Examine homologous regions across subjects
    - Improve anatomical specificity
    - Improve sensitivity
  - Report findings in a common anatomical space (e.g. MNI space)

# T&T atlas vs MNI template

---

The Talairach & Tournoux Atlas    The MNI/ICBM AVG152 Template

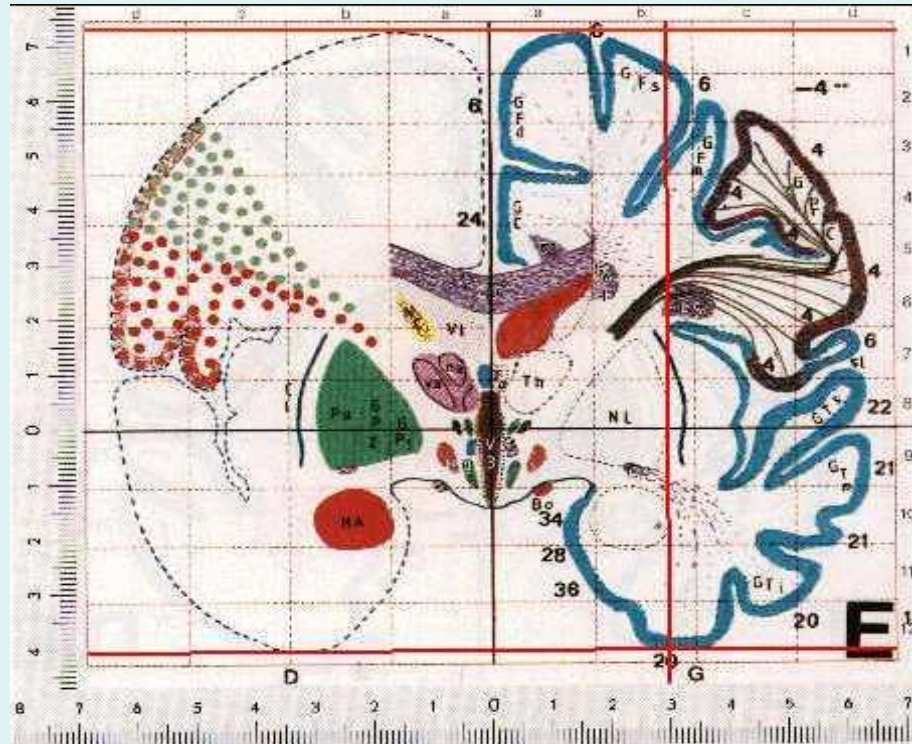

The MNI template follows the *convention* of T&T, but does NOT match the *particular brain*

Recommended reading: <http://imaging.mrc-cbu.cam.ac.uk/imaging/MniTalairach>

# Between subjects

---

- Brains of different subjects vary in *shape* and *size*.
  - Need to bring them all into a common anatomical space.
  - Examine homologous regions across subjects
    - Improve anatomical specificity
    - Improve sensitivity
  - Report findings in a common anatomical space (e.g. MNI space)
- In SPM12, alignment is achieved by matching tissue classes, i.e. GM with GM, WM with WM,...

# Normalise/Segment

- This is the same algorithm as for tissue segmentation.
- Combines:
  - Mixture of Gaussians (MOG)
  - Bias Correction Component
  - Warping (Non-linear Registration) Component

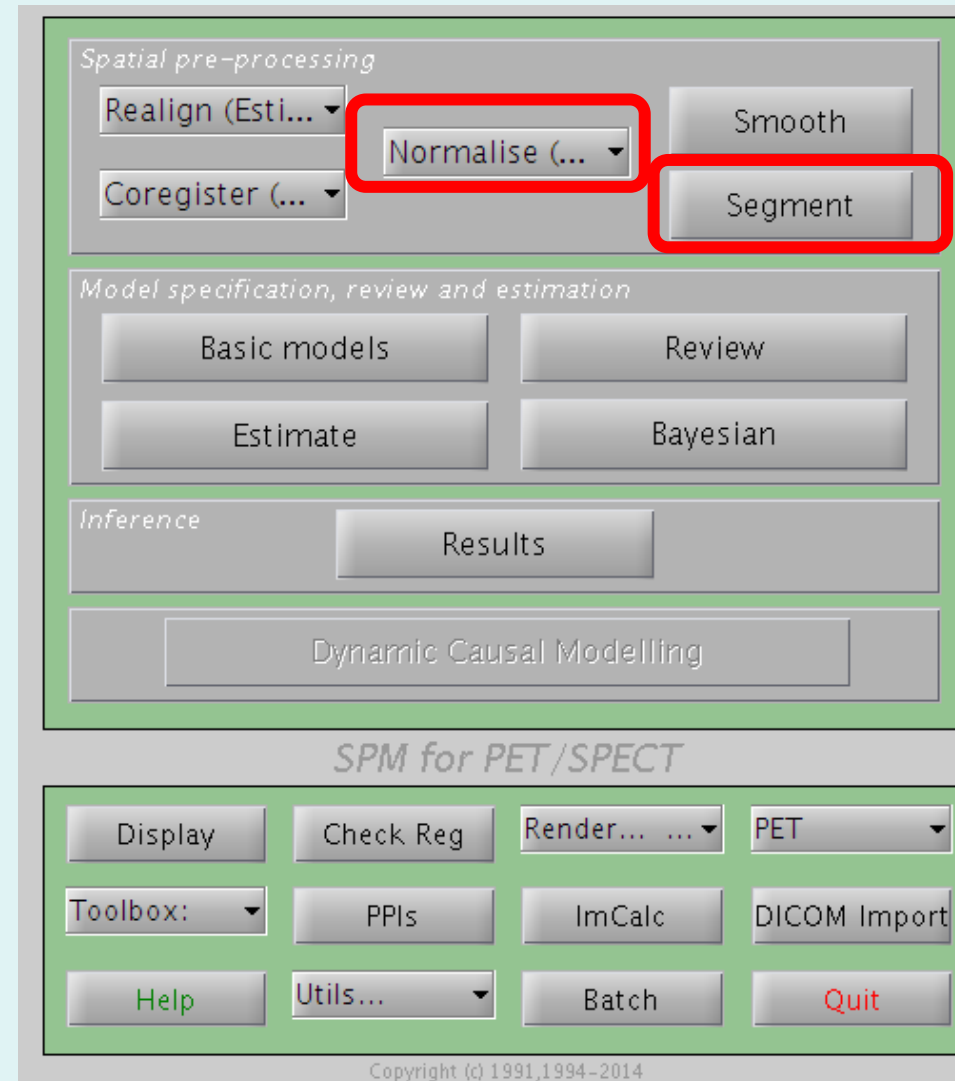

# Spatial normalisation

- Default spatial normalisation in SPM12 estimates nonlinear warps that match tissue probability maps to the individual image.
- Spatial normalisation achieved using the inverse of this transform.

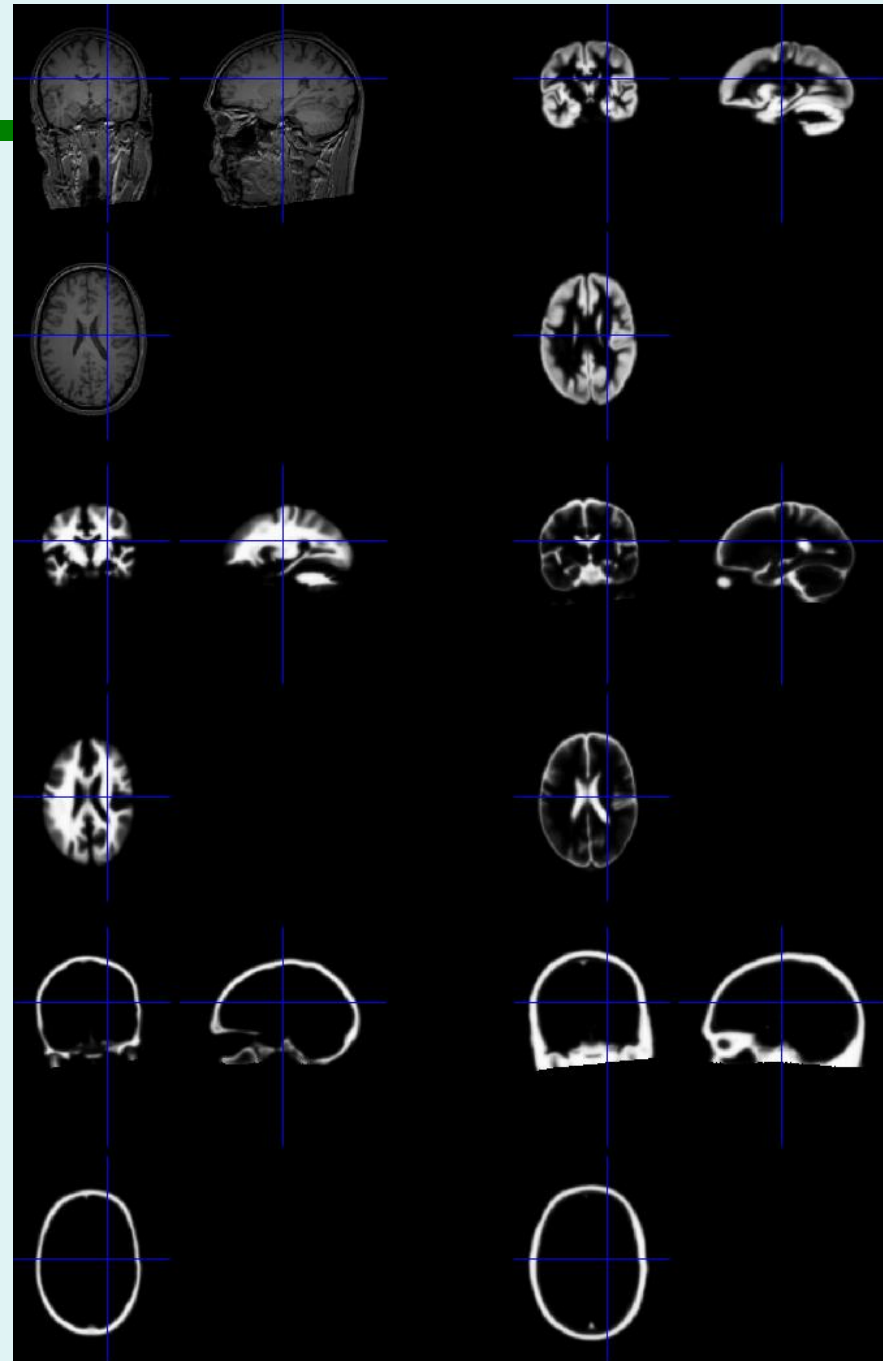

# Segmentation

- Segmentation in SPM12 also estimates a spatial transformation that can be used for spatially normalising images.
- It uses a **generative model**, which involves:
  - Mixture of Gaussians (MOG)
  - Warping (Non-linear Registration) Component
  - Bias Correction Component

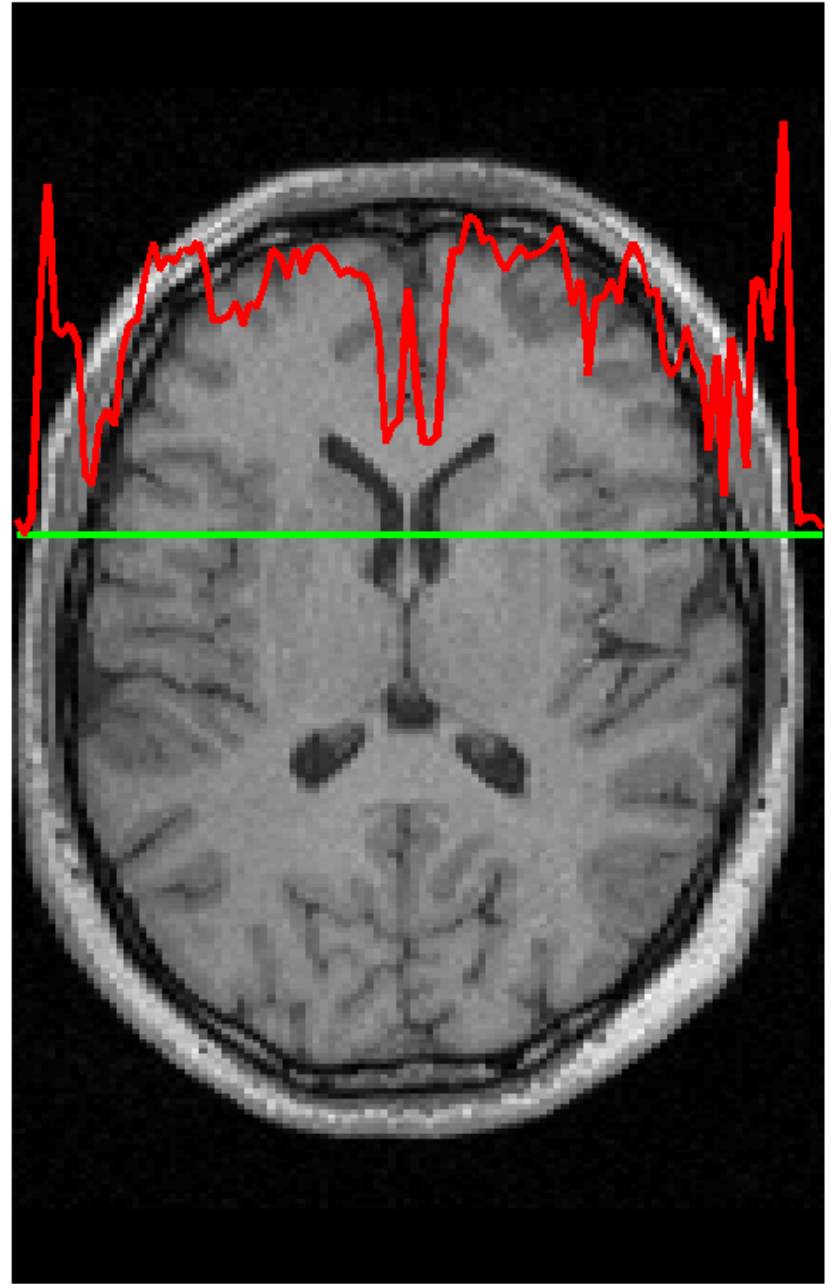



# Tissue intensity distributions (T1w-MRI)

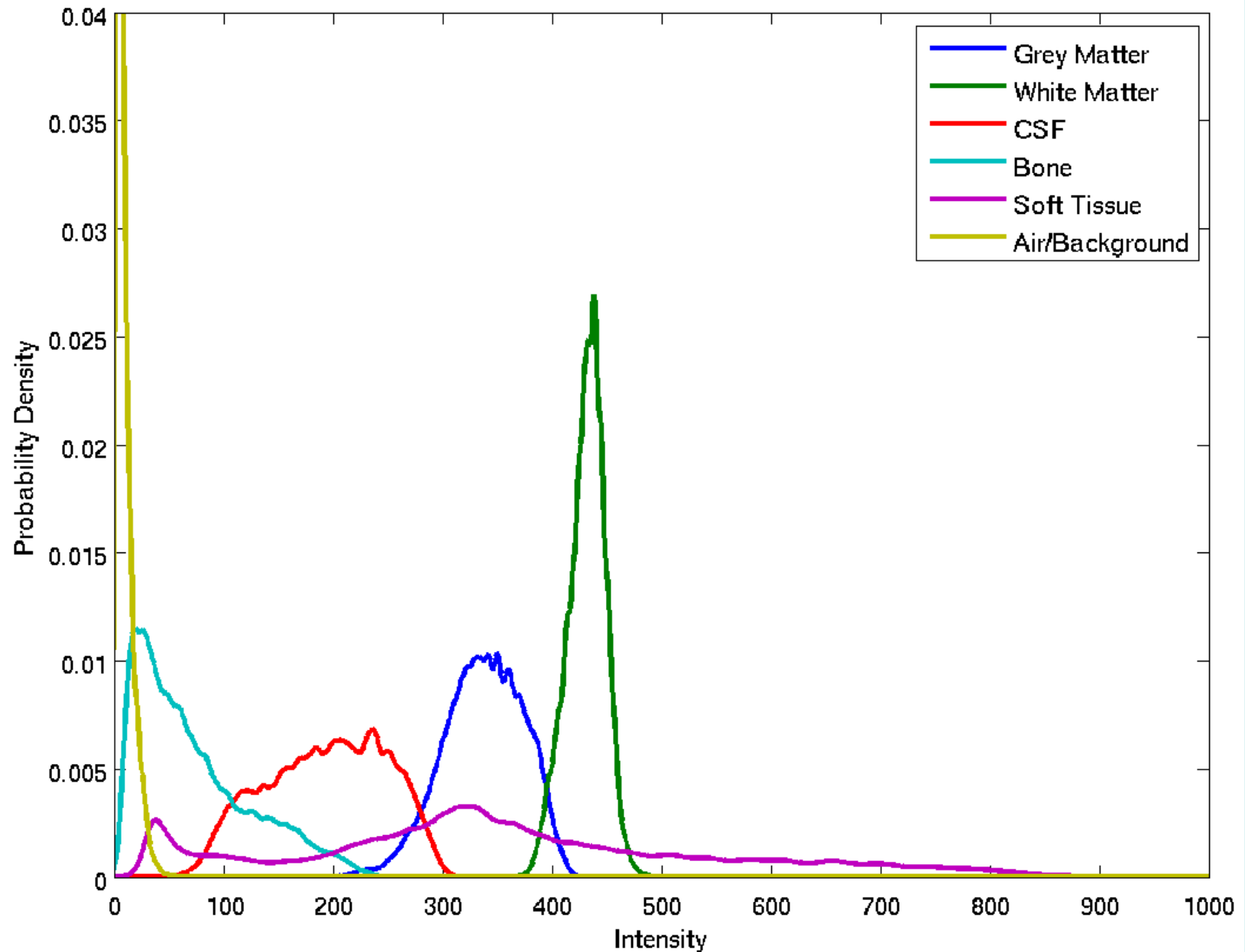

# TPM's

---

Tissue probability maps in SPM12.

- GM, WM & CSF
  - Additional non-brain tissue classes
- define the template space !

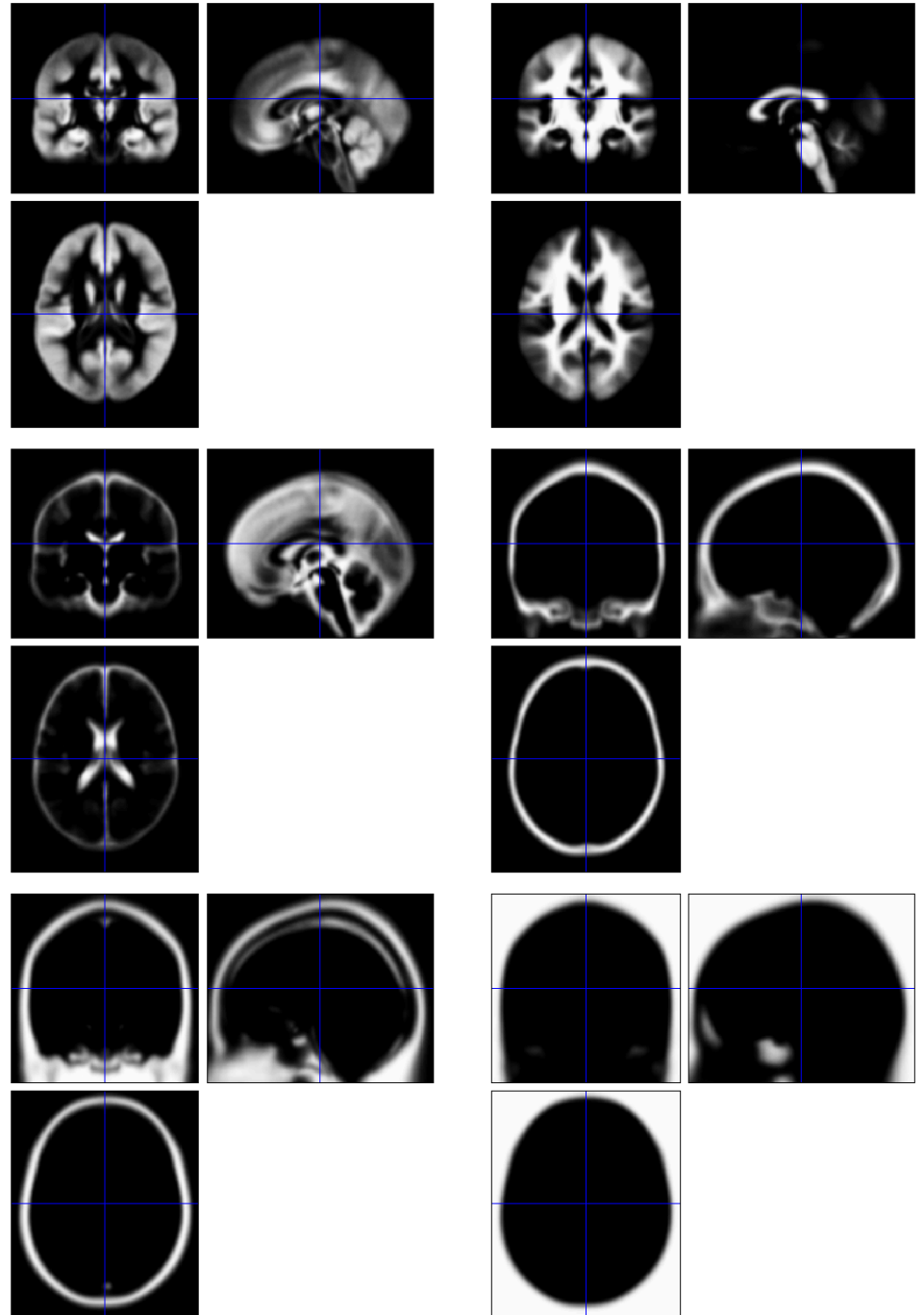

# Modelling deformations, affine transform

## 12 parameter affine transform

- 3 translations
- 3 rotations
- 3 zooms
- 3 shears

$$\begin{bmatrix} x_1 \\ y_1 \\ z_1 \\ 1 \end{bmatrix} = \begin{bmatrix} m_{11} & m_{12} & m_{13} & m_{14} \\ m_{21} & m_{22} & m_{23} & m_{24} \\ m_{31} & m_{32} & m_{33} & m_{34} \\ 0 & 0 & 0 & 1 \end{bmatrix} \times \begin{bmatrix} x_0 \\ y_0 \\ z_0 \\ 1 \end{bmatrix}$$

→ Fits **overall** shape and size

→ Need *warping* for local deformation

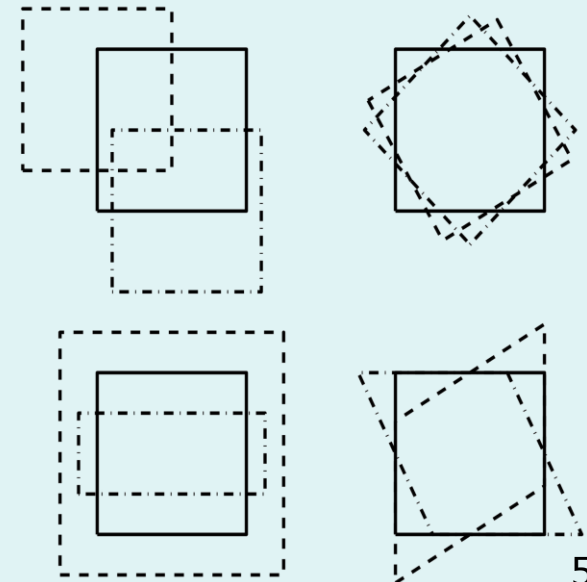

# Spatial normalisation results

---

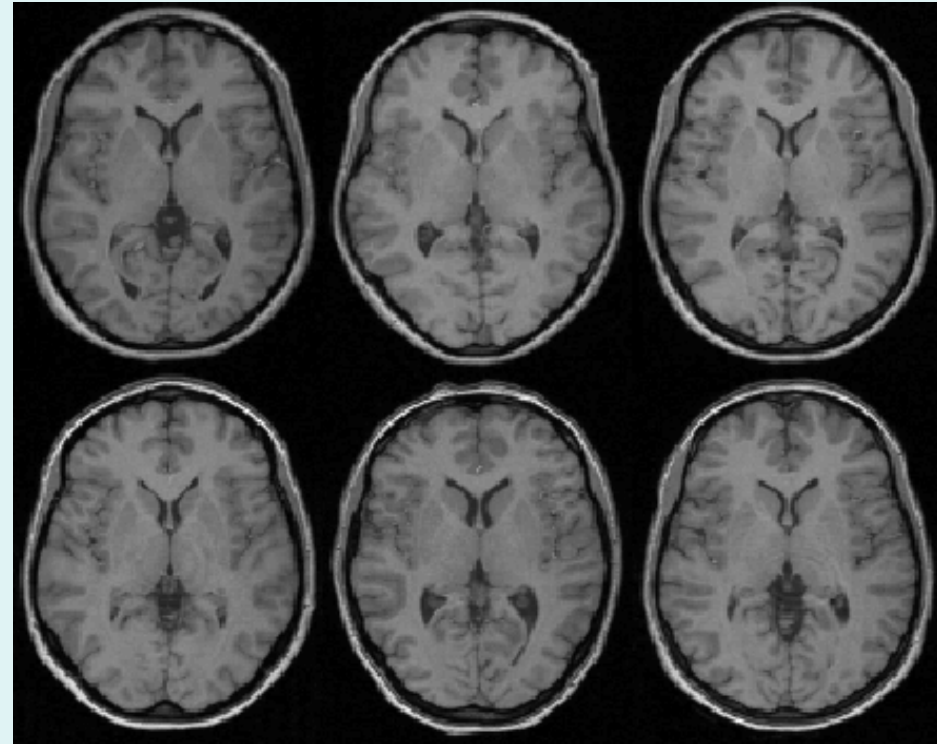

Affine registration

# Modelling elastic deformations, “warps”

---

- Tissue probability images are warped to match the subject
- The inverse transform warps to the TPMs
- Warps are constrained to be *reasonable* by penalising extreme distortions (bending energy)

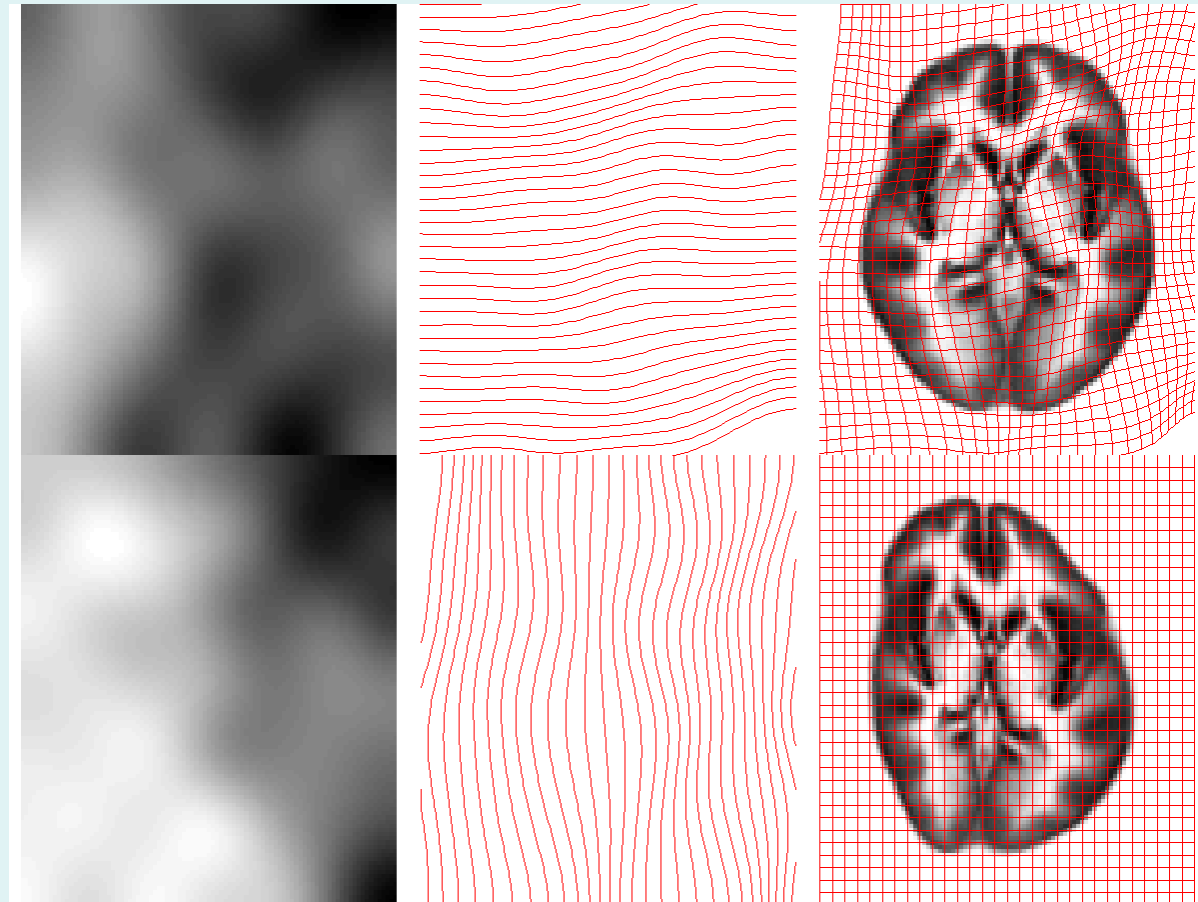

# Non-linear warping, example

For every voxel position in blank sheet

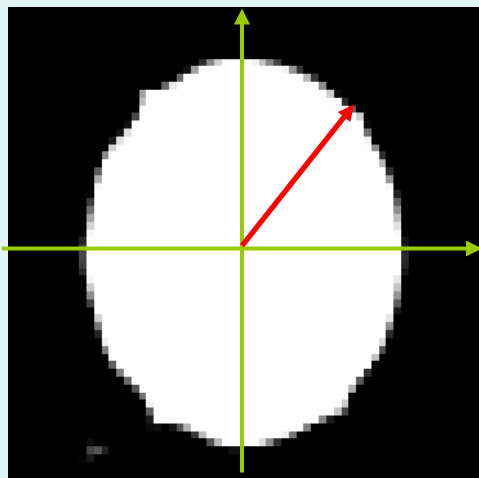

$$\begin{bmatrix} x' \\ y' \end{bmatrix} = \begin{bmatrix} x \\ y \end{bmatrix} + \begin{bmatrix} d_x(x, y) \\ d_y(x, y) \end{bmatrix}$$

Go to original image and find intensity at warped co-ordinate

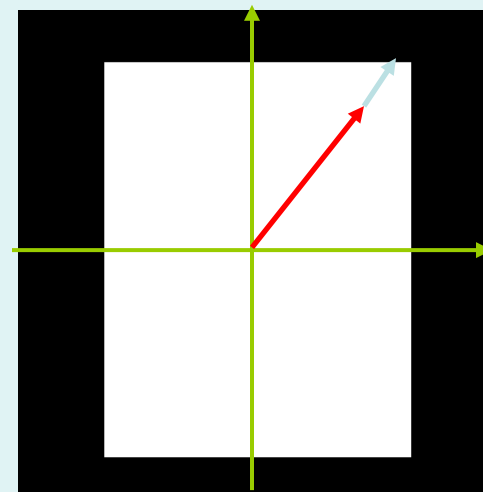

Get position in original space by adding pertinent displacement

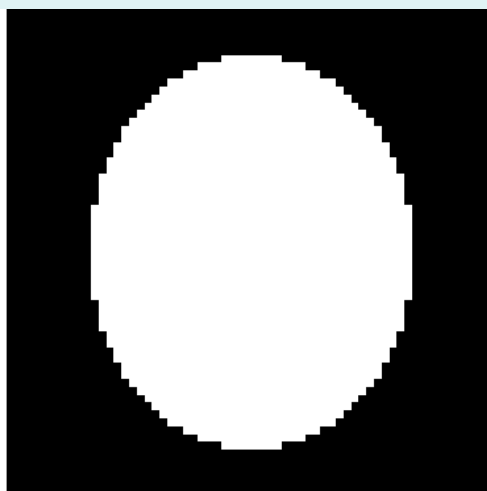
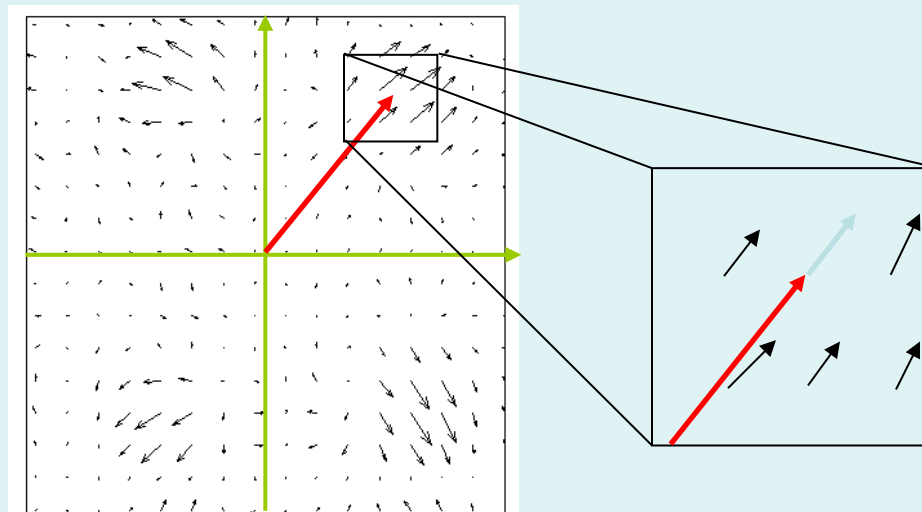

# Non-linear warping, example

For each voxel-centre in blank sheet.

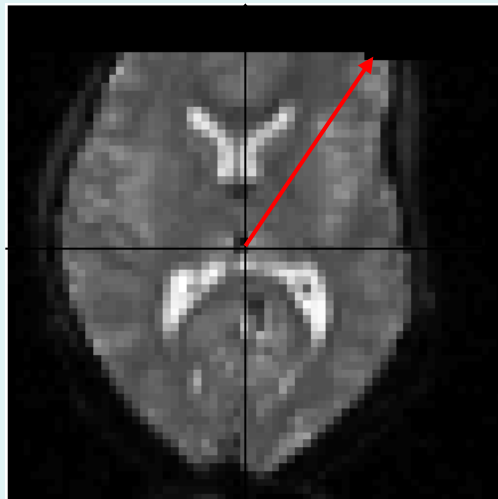

Go to original image and find intensity at "warped" co-ordinate

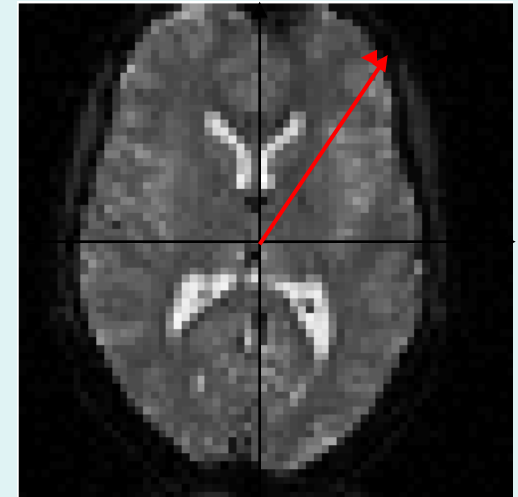

Get position in original space by adding pertinent displacement.

$$\begin{bmatrix} x' \\ y' \end{bmatrix} = \begin{bmatrix} x \\ y \end{bmatrix} + \begin{bmatrix} d_x(x, y) \\ d_y(x, y) \end{bmatrix}$$

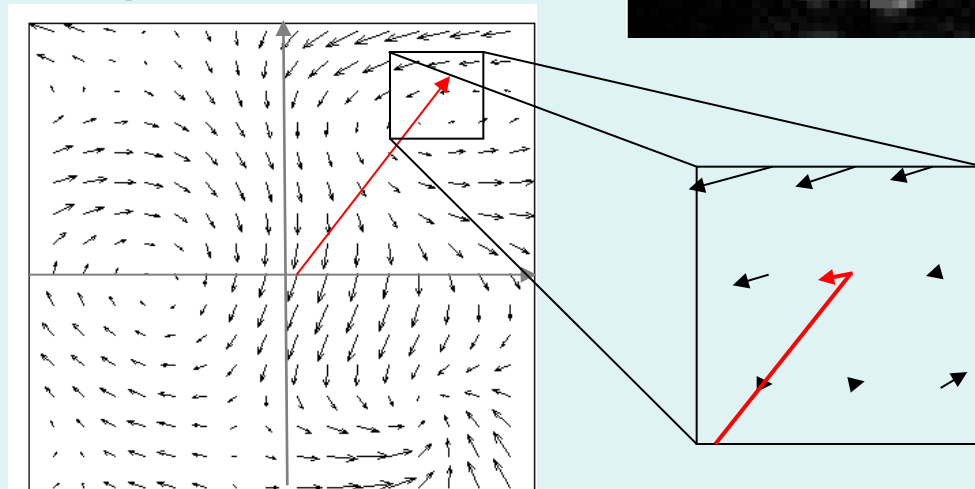

# Displacement map

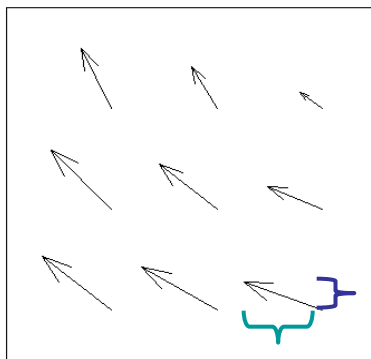
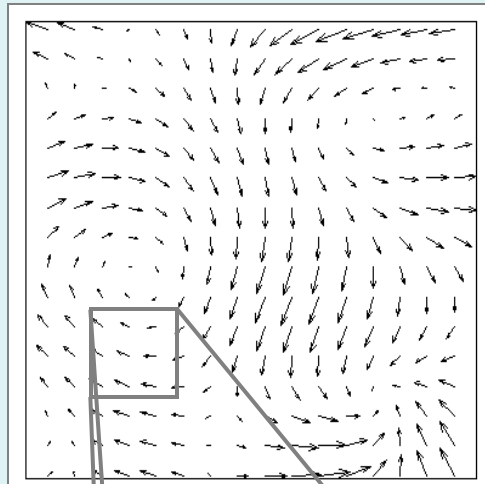

x-displacement

y-displacement,  
**black**: downward translation  
**white**: upward translation  
**grey**: no translation

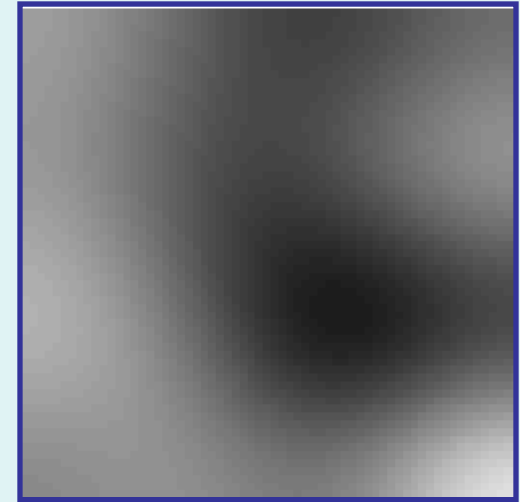

x-displacement,  
**black**: leftward translation  
**white**: rightward translation  
**gray**: no translation

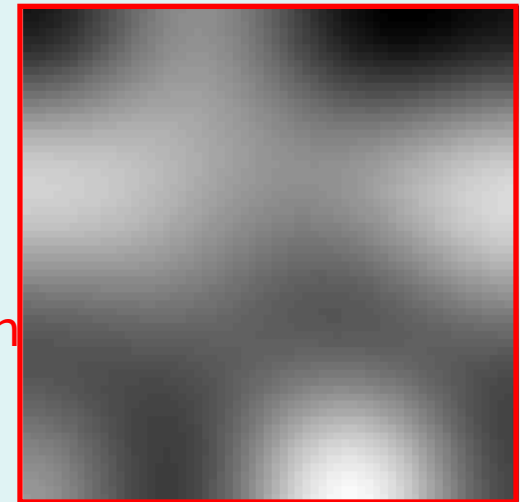



# Displacement map modelling

- To prevent impossible deformations we restrict it to be a linear combination of permitted basis-warps.
- For example use the discrete cosine set  $\rightarrow$  smooth deformation!

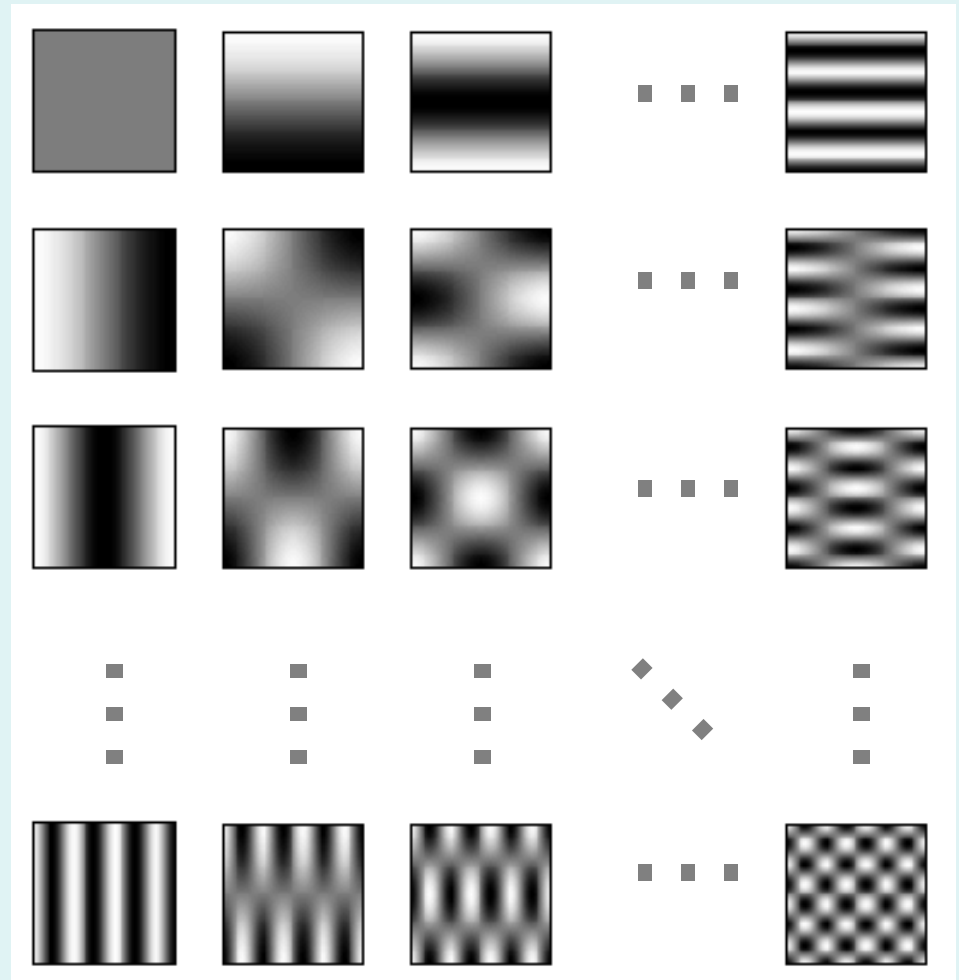

# Displacement maps, example

Square-to-ellipse map

Each basis-warp multiplied by a weight

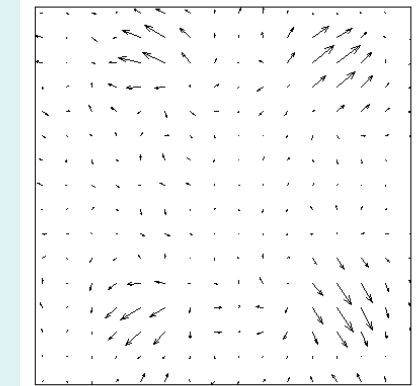
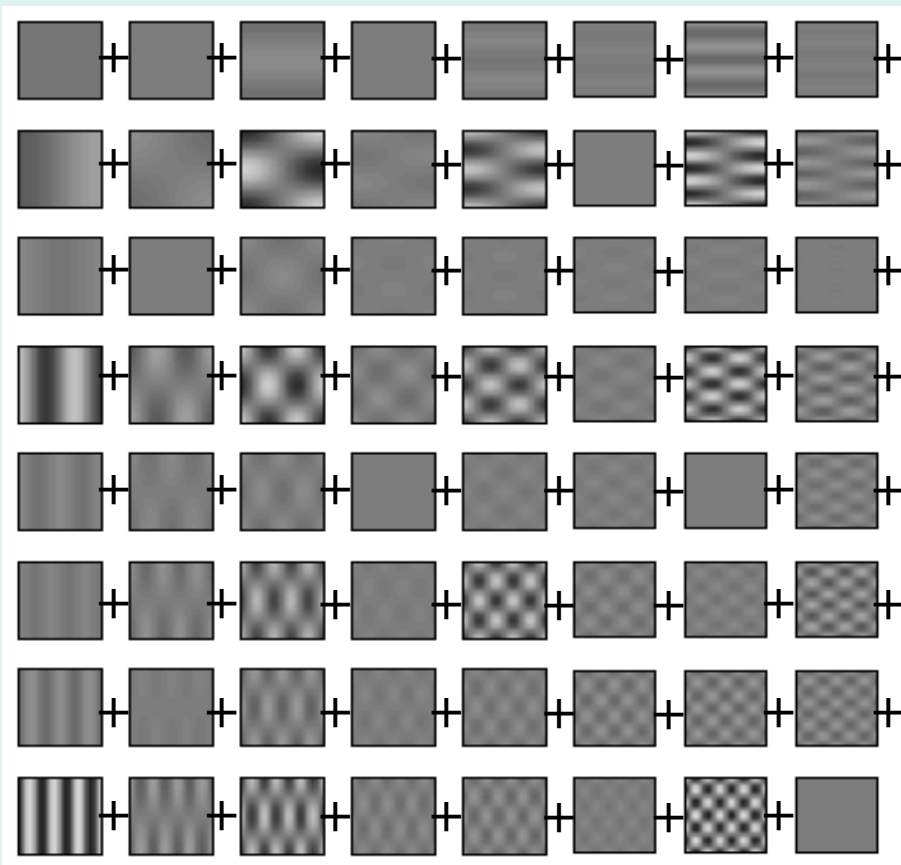

x-component of  
square-to-ellipse map

=

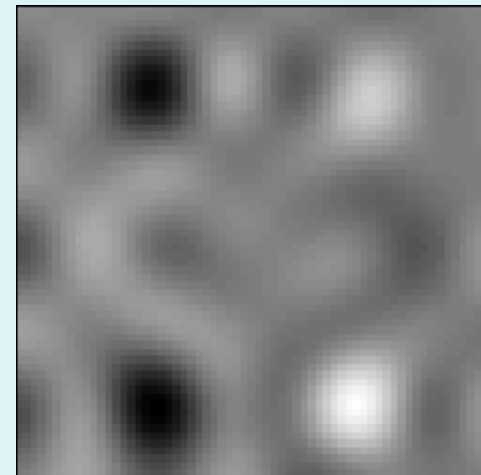

# Displacement maps, example

Dark - shift left, Light - shift right



Deformation Field in X

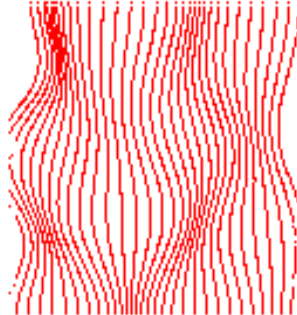

Field Applied To Image

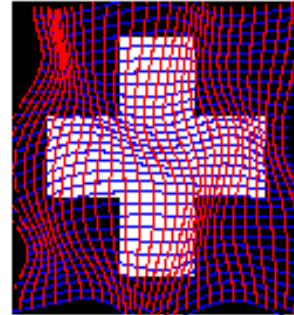

Dark - shift down, Light - shift up



Deformation Field in Y

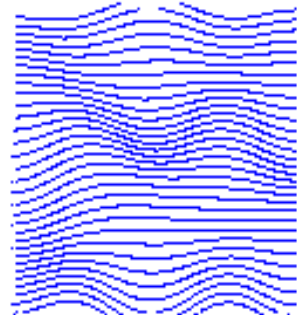

Deformed Image

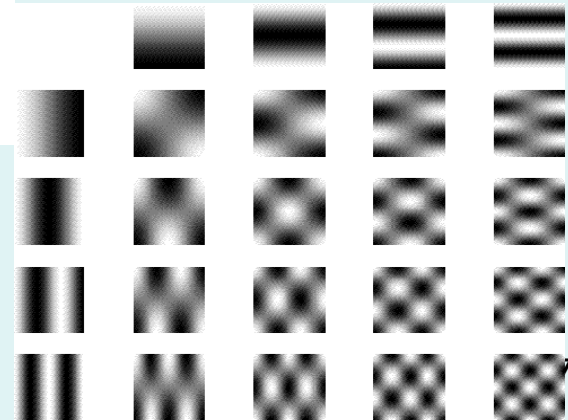
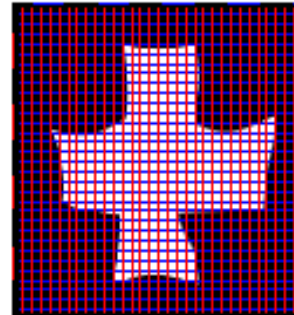

# Modelling deformations, warps

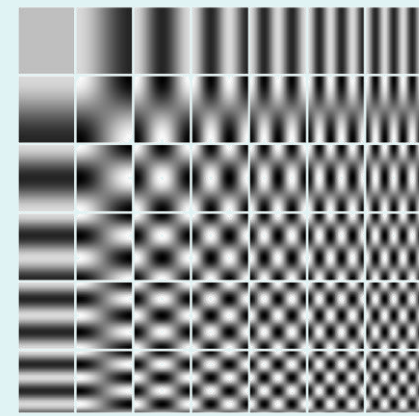

- Tissue probability images are warped to match the subject
- The inverse transform warps to the TPMs
- Warps are constrained to be reasonable by penalising various distortions (energies)

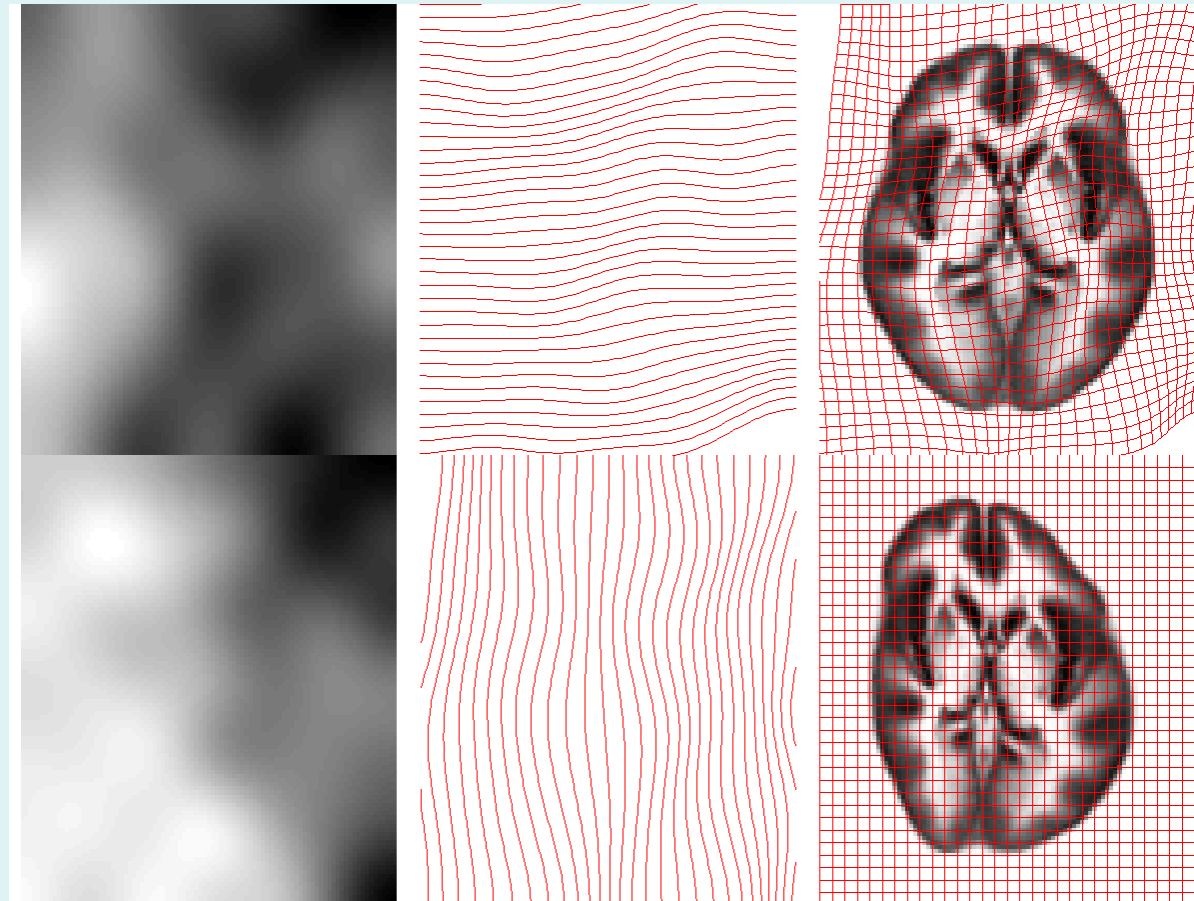

# Spatial normalisation results

---

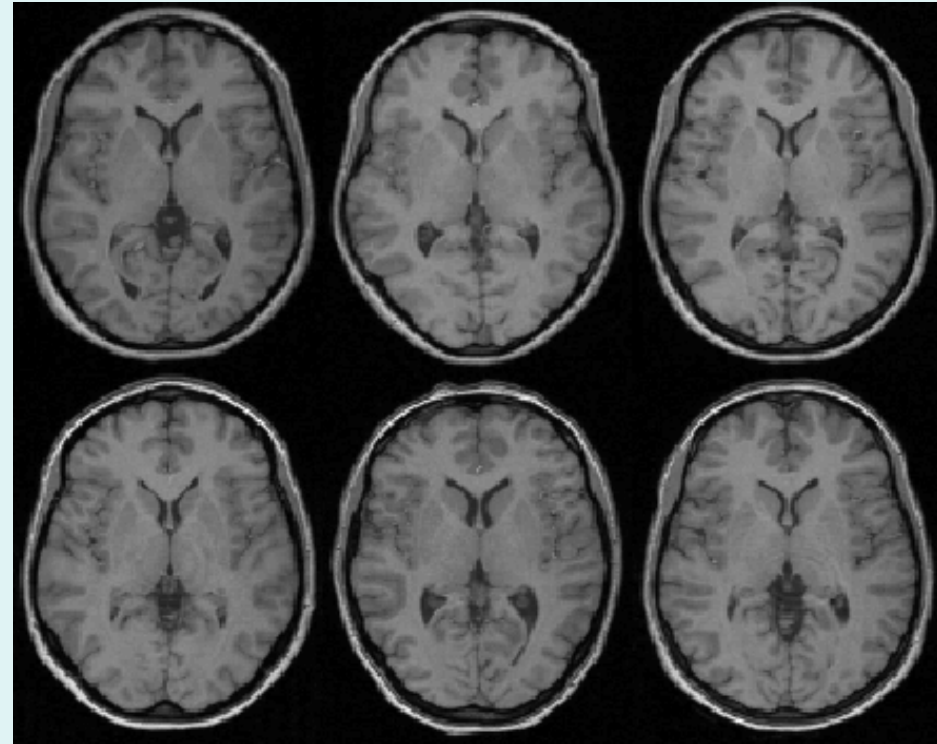

Affine registration

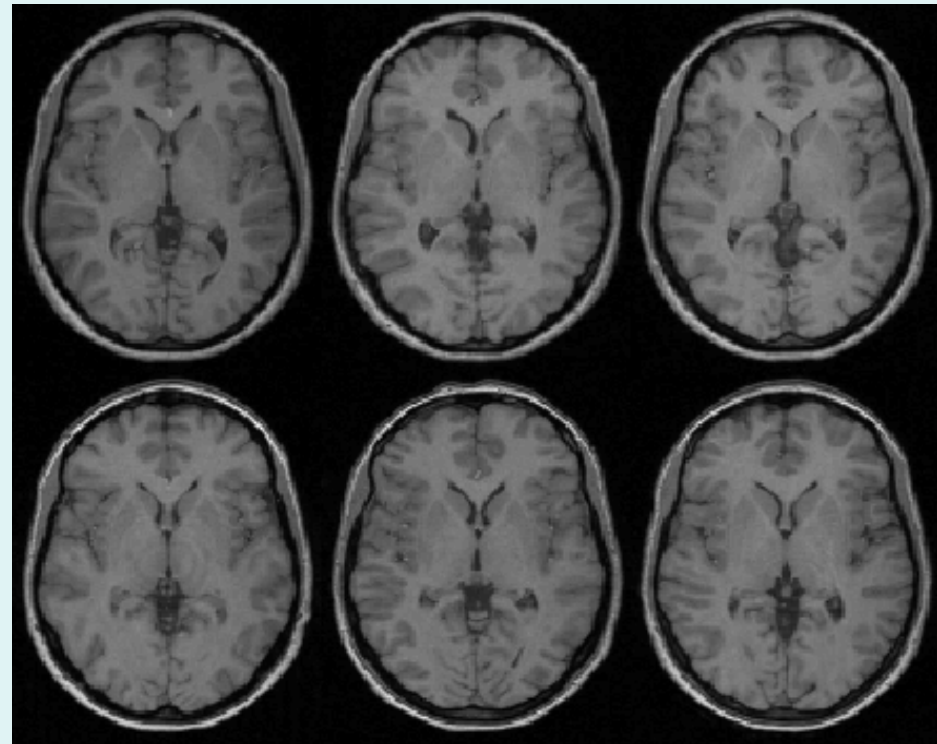

Non-linear registration

# Modelling inhomogeneity

A multiplicative bias field is modelled as a spatially smooth image

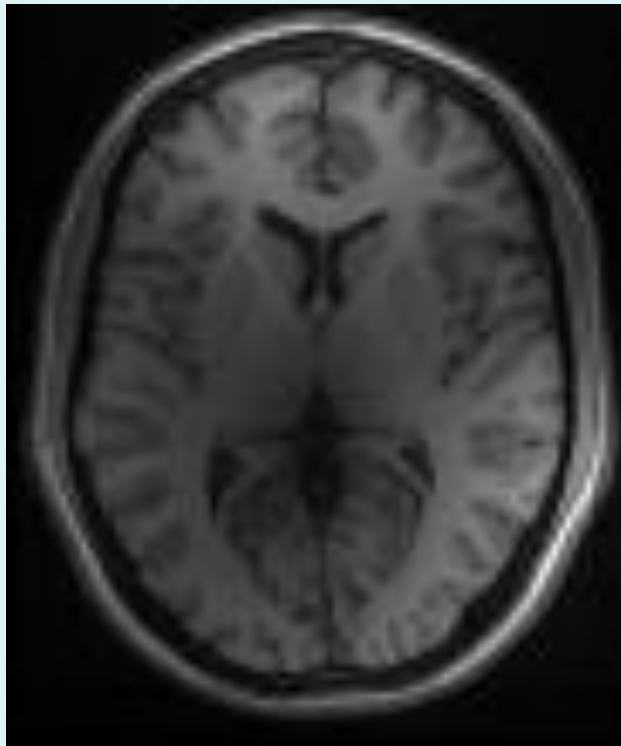
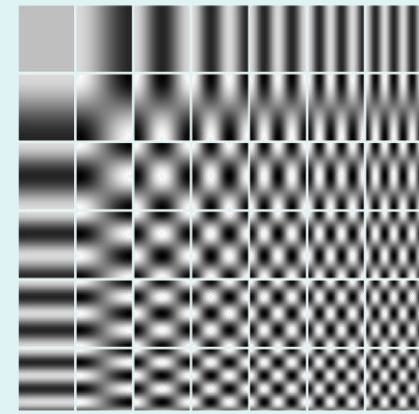

**Corrupted image**

**Bias Field**

**Corrected image**

# Normalisation & Unified Segmentation

---

- MRI imperfections make normalisation harder
  - Differences between sequences, artefacts
  - Intensity inhomogeneity or “bias” field
- Normalising *segmented tissue maps* should be more robust and precise than using the original images ...
- ... Tissue segmentation benefits from spatially-aligned *prior tissue probability maps* (from other segmentations)

→ Circular reasoning!

# Iterative optimisation scheme

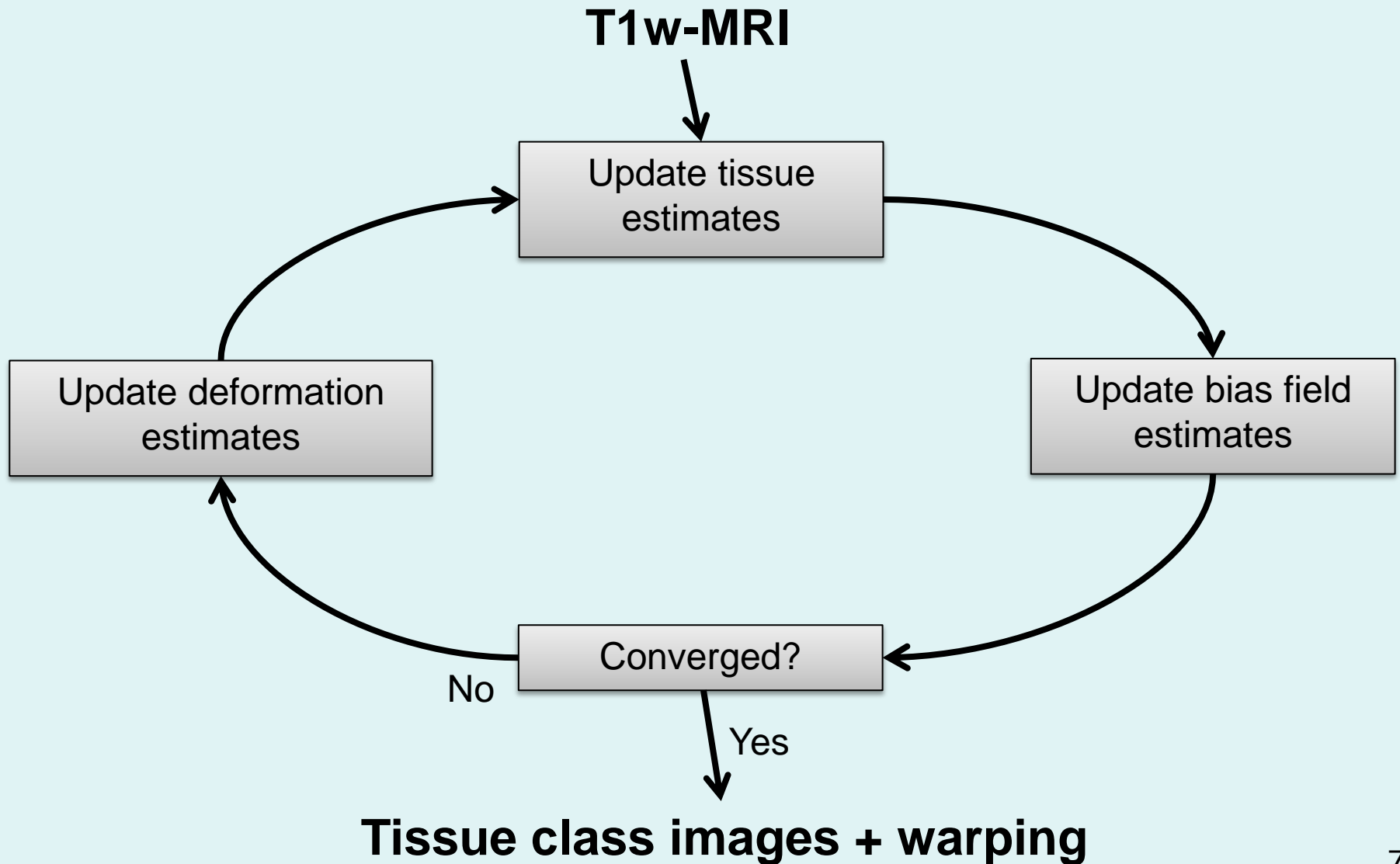



# Segmentation results

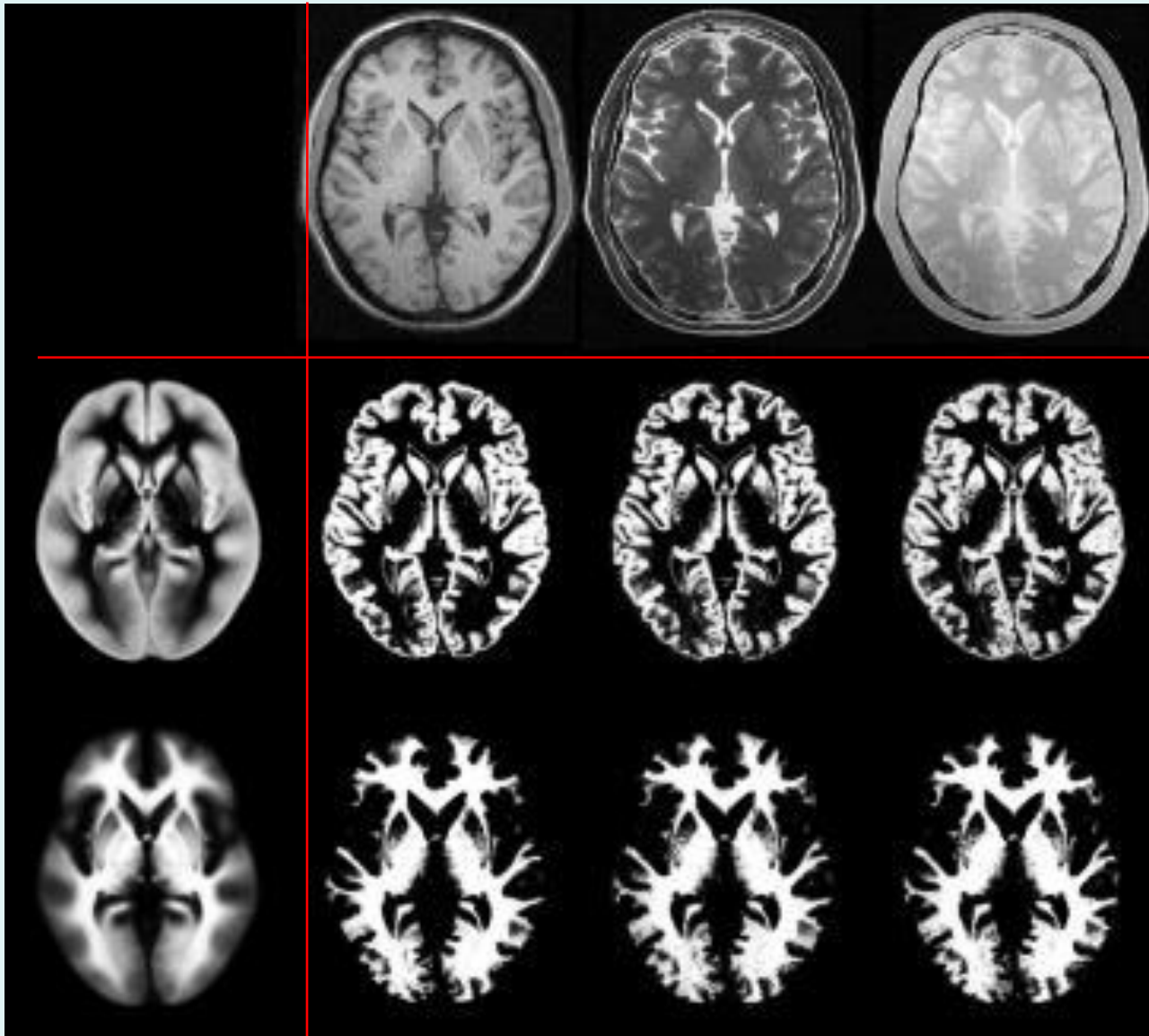

Spatially  
normalised  
BrainWeb  
phantoms  
(T1, T2,  
PD)

Tissue  
probability  
maps of  
GM and  
WM

# Tissue intensity distributions (T1w-MRI)

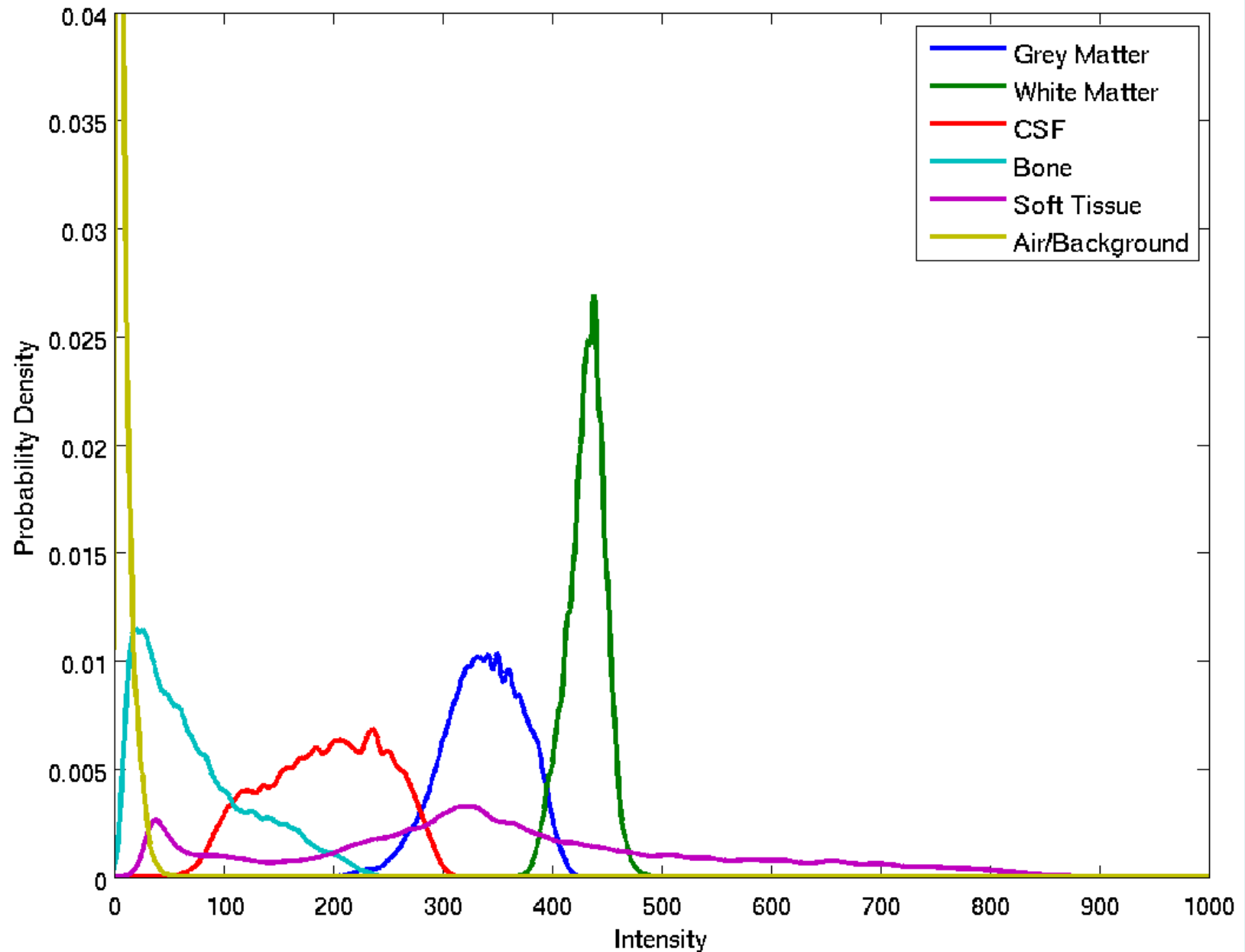

# Mixture of Gaussians (MoG)

Classification is based on a Mixture of Gaussians model (MOG), which represents the intensity probability density by a number of **Gaussian distributions**.

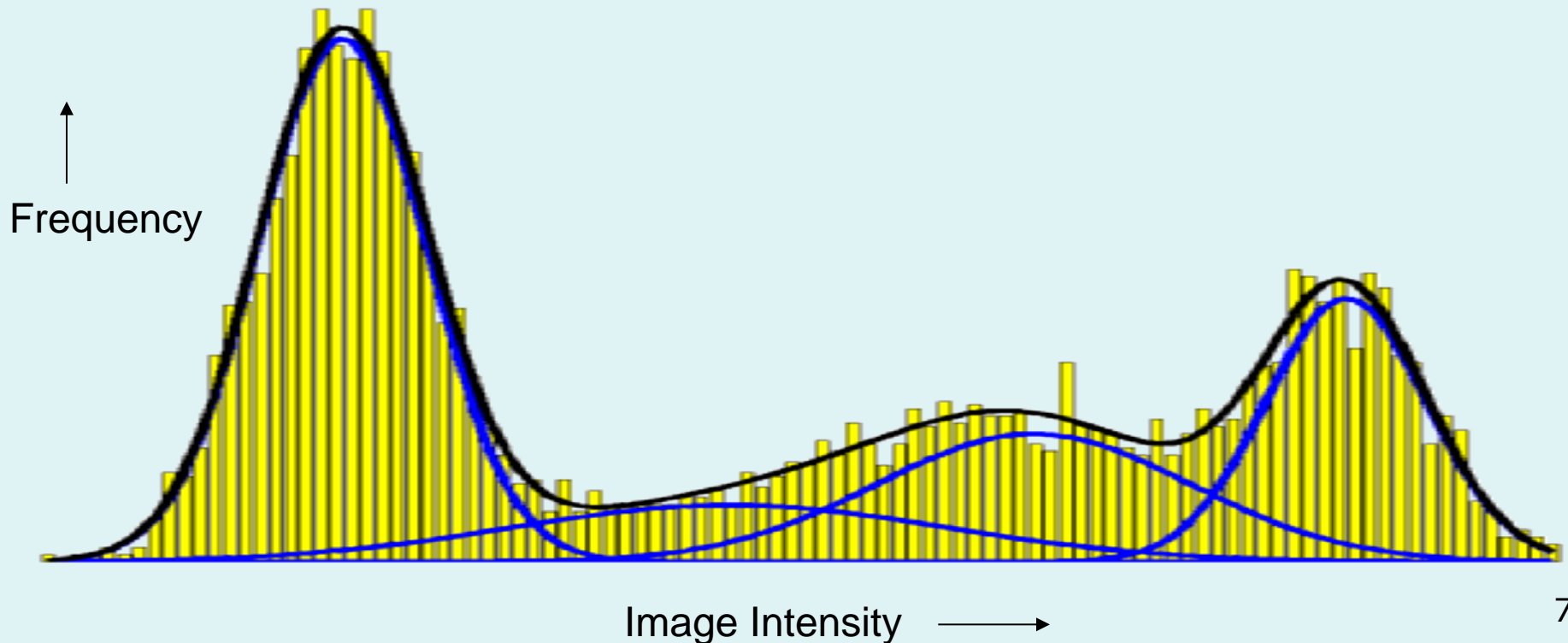

# Gaussian probability density

If intensities are assumed to be Gaussian of mean  $\mu_k$  and variance  $\sigma_k^2$ , then the probability of a value  $y_i$  is:

$$P(y_i | \mu_k, \sigma_k^2) = \frac{1}{\sqrt{2\pi\sigma_k^2}} \exp\left(-\frac{(y_i - \mu_k)^2}{2\sigma_k^2}\right)$$

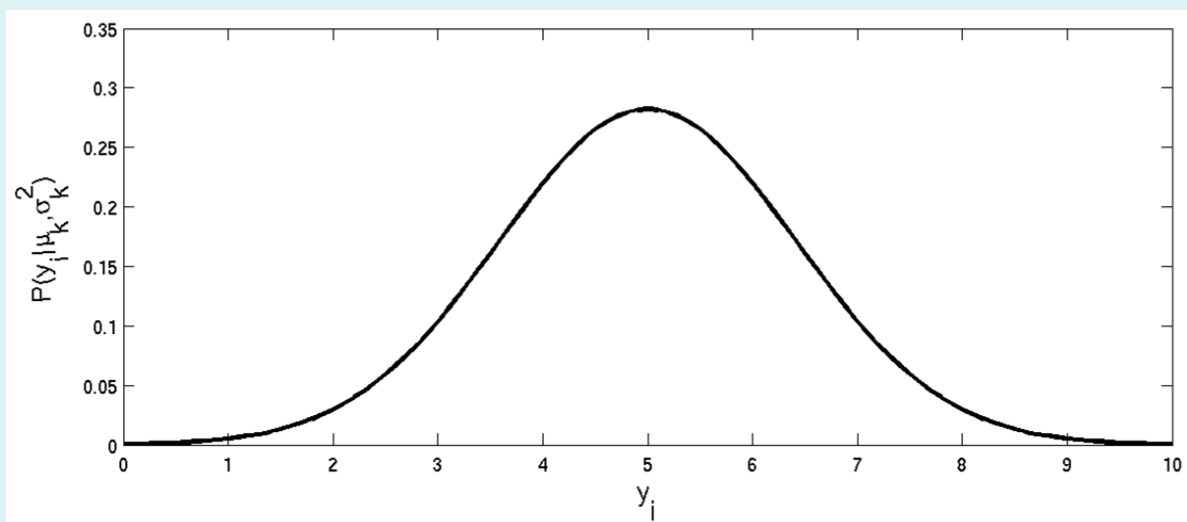

# Non-Gaussian probability density

A non-Gaussian probability density function can be modelled by a Mixture of Gaussians (MOG):

$$P(y_i | \mu, \sigma^2, \gamma) = \sum_{k=1}^K \gamma_k \frac{1}{\sqrt{2\pi\sigma_k^2}} \exp\left(-\frac{(y_i - \mu_k)^2}{2\sigma_k^2}\right)$$

Mixing proportion - positive and sums to one

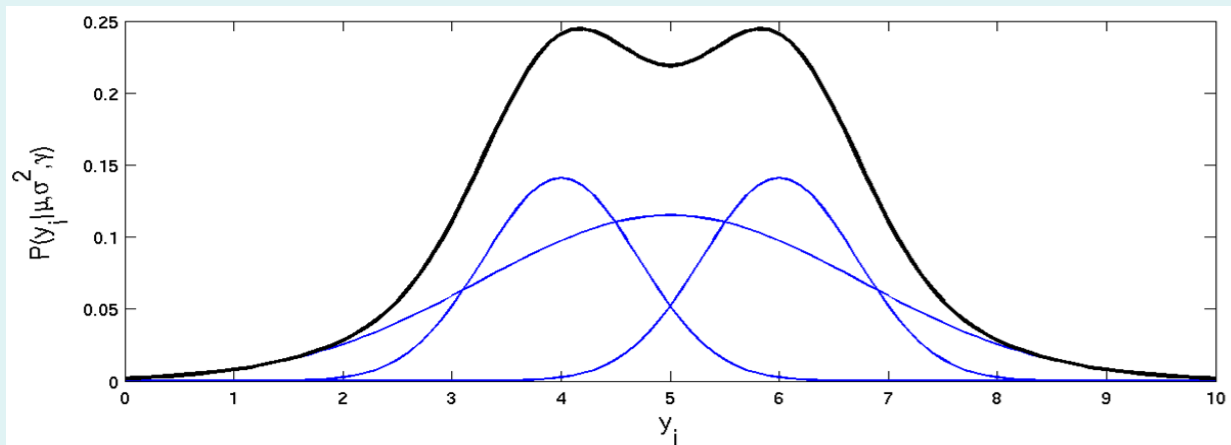

# Mixing proportions

- The mixing proportion  $\gamma_k$  represents the prior probability of a voxel being drawn from class  $k$  - irrespective of its intensity.

$$P(c_i = k | \gamma) = \gamma_k$$

- So:

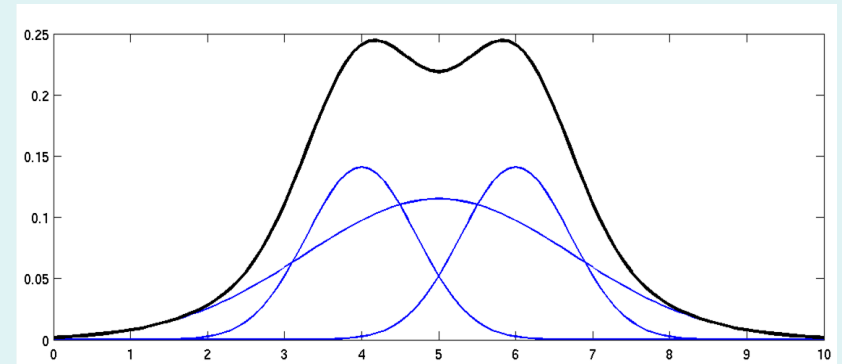

$$\begin{aligned} P(y_i | \mu, \sigma^2, \gamma) &= \sum_{k=1}^K P(y_i, c_i = k | \mu, \sigma^2, \gamma) \\ &= \sum_{k=1}^K P(c_i = k | \gamma) P(y_i | c_i = k, \mu, \sigma^2) \end{aligned}$$

# Probability of whole image

- If the voxels are assumed to be independent, then the probability of the whole image is the product of the probabilities of each voxel:

$$P(\mathbf{y} \mid \mu, \sigma^2, \gamma) = \prod_{i=1}^I P(y_i \mid \mu, \sigma^2, \gamma)$$

- It is often easier to work with negative log-probabilities:

$$-\log(P(\mathbf{y} \mid \mu, \sigma^2, \gamma)) = -\sum_{i=1}^I \log(P(y_i \mid \mu, \sigma^2, \gamma))$$

# Modelling a bias field

- A bias field is included, such that the required scaling at voxel  $i$ , parameterised by  $\beta$ , is  $\rho_i(\beta)$ .
- Replace the means by  $\mu_k / \rho_i(\beta)$
- Replace the variances by  $(\sigma_k / \rho_i(\beta))^2$

$$P(y_i | c_i = k, \mu, \sigma^2, \beta) = \frac{1}{\sqrt{2\pi(\sigma_k / \rho_i(\beta))^2}} \exp\left(-\frac{(y_i - \mu_k / \rho_i(\beta))^2}{2(\sigma_k / \rho_i(\beta))^2}\right)$$



# Modelling a bias field

After rearranging:

$$P(y_i | c_i = k, \mu, \sigma^2, \beta) = \frac{\rho(\beta)}{\sqrt{2\pi\sigma_k^2}} \exp\left(-\frac{(y_i\rho_i(\beta) - \mu_k)^2}{2\sigma_k^2}\right)$$

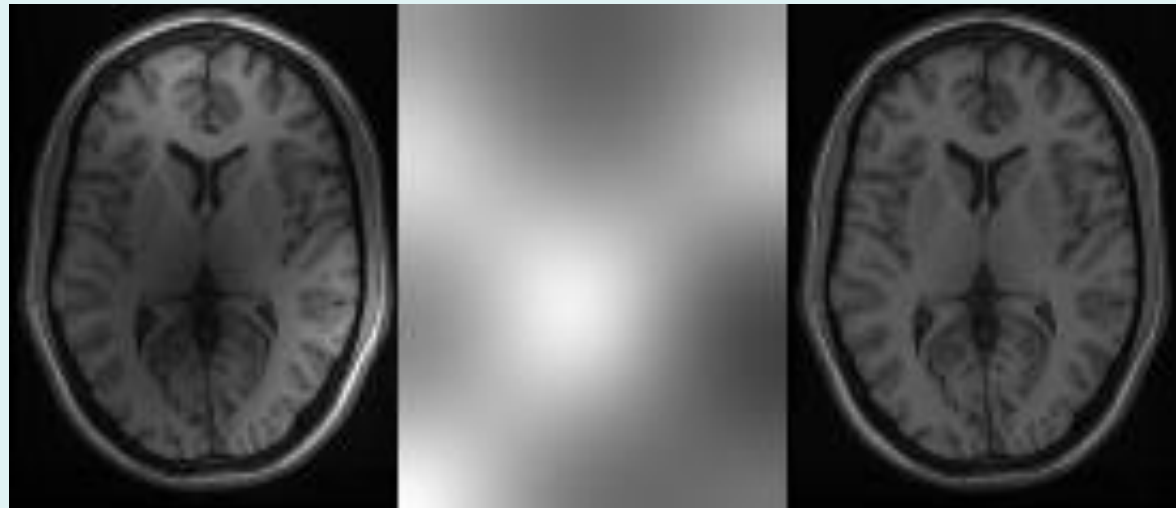
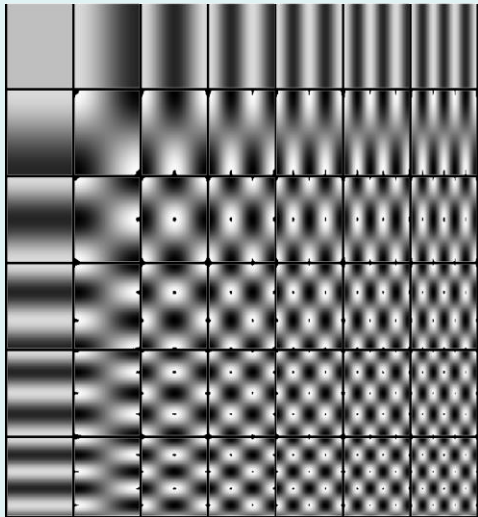

**y**

$\rho(\beta)$

**y**  $\rho(\beta)$

# “Mixing proportions”

- Tissue probability maps for each class are included.
- The probability of obtaining class  $k$  at voxel  $i$ , given weights  $\gamma$  is then:

$$P(c_i = k | \gamma) = \frac{\gamma_k b_{ik}}{\sum_{j=1}^K \gamma_j b_{ij}}$$

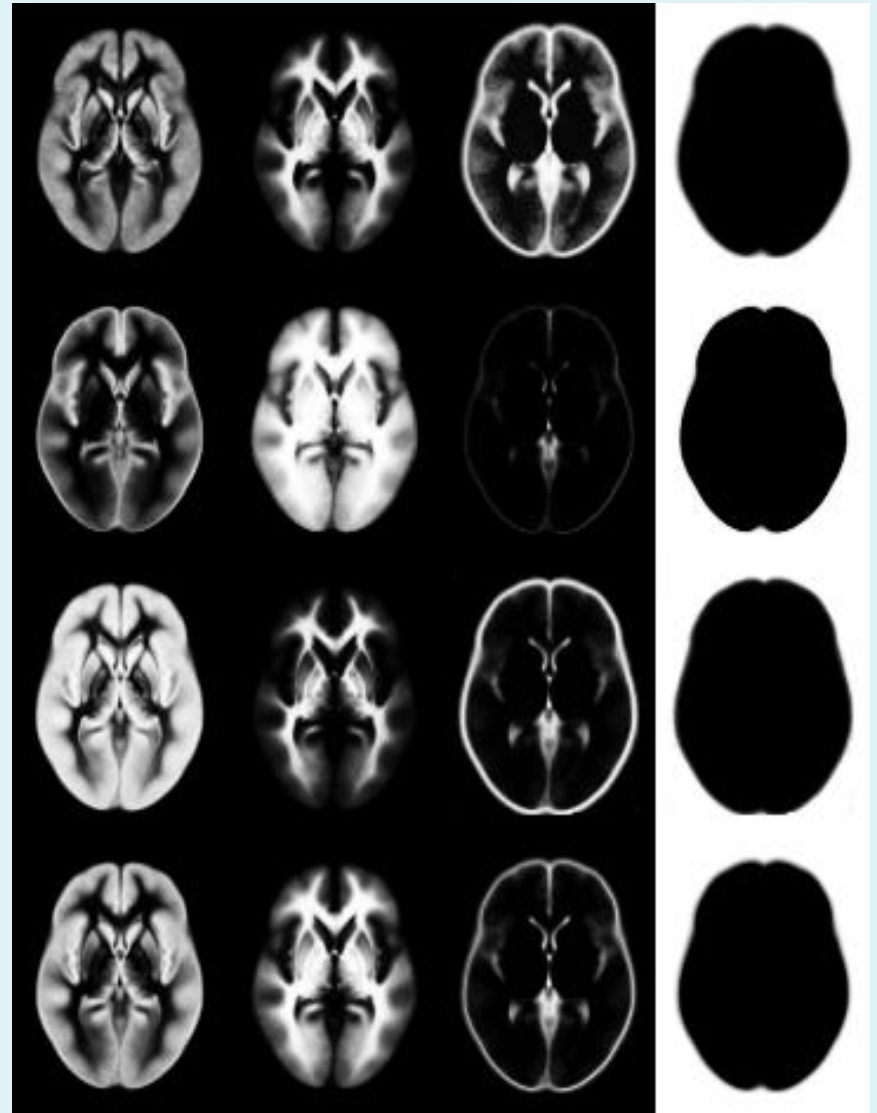

# TPMs deformation

- Tissue probability images are deformed according to parameters  $\alpha$ .
- The probability of obtaining class  $k$  at voxel  $i$ , given weights  $\gamma$  and parameters  $\alpha$  is then:

$$P(c_i = k \mid \gamma, \alpha) = \frac{\gamma_k \mathbf{b}_{ik}(\alpha)}{\sum_{j=1}^K \gamma_j \mathbf{b}_{ij}(\alpha)}$$

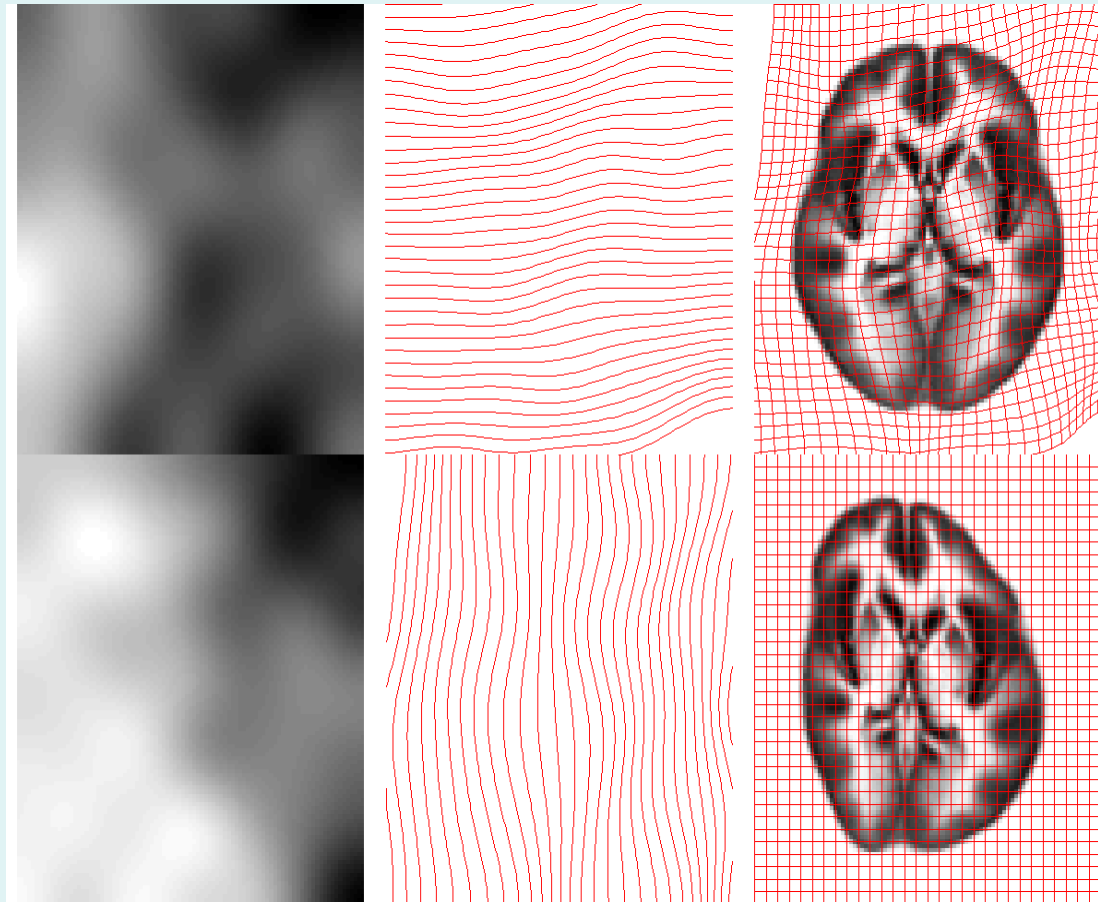

# The extended US model

- By combining the modified  $P(c_i=k|\theta)$  and  $P(y_i|c_i=k,\theta)$ , the overall objective function (E) becomes:

$$E = -\sum_{i=1}^I \log [P(y_i|\theta)] = -\sum_{i=1}^I \log \left[ \sum_{k=1}^K P(c_i = k | \theta) P(y_i | c_i = k, \theta) \right]$$

$$= -\sum_{i=1}^I \log \left[ \rho_i(\beta) \sum_{k=1}^K \frac{\gamma_k \mathbf{b}_{ik}(\alpha)}{\sum_{j=1}^K \gamma_j \mathbf{b}_{ij}(\alpha)} \frac{1}{\sqrt{2\pi\sigma_k^2}} \exp \left( -\frac{(\rho_i(\beta)\gamma_i - \mu_k)^2}{2\sigma_k^2} \right) \right]$$

**The Objective Function**

# Optimisation

- The “best” parameters are those that minimise this objective function.
- Optimisation involves finding them.
- Begin with starting estimates, and repeatedly change them so that the objective function decreases each time.

$$E = -\sum_{i=1}^I \log \left[ \rho_i(\beta) \sum_{k=1}^K \frac{\gamma_k b_{ik}(\alpha)}{\sum_{j=1}^K \gamma_j b_{ij}(\alpha)} \frac{1}{\sqrt{2\pi\sigma_k^2}} \exp\left(-\frac{(\rho_i(\beta)\gamma_i - \mu_k)^2}{2\sigma_k^2}\right) \right]$$

# Optimisation strategy

---

Repeat until convergence...

- Hold  $\gamma$ ,  $\mu$ ,  $\sigma^2$  and  $\alpha$  constant, and minimise  $E$  w.r.t.  $\beta$   
Levenberg-Marquardt strategy, using  $dE/d\beta$  and  $d^2E/d\beta^2$
- Hold  $\gamma$ ,  $\mu$ ,  $\sigma^2$  and  $\beta$  constant, and minimise  $E$  w.r.t.  $\alpha$   
Levenberg-Marquardt strategy, using  $dE/d\alpha$  and  $d^2E/d\alpha^2$
- Hold  $\alpha$  and  $\beta$  constant, and minimise  $E$  w.r.t.  $\gamma$ ,  $\mu$  and  $\sigma^2$   
Use an Expectation Maximisation (EM) strategy.

end

# Spatial normalisation, overfitting

Without regularisation, the non-linear spatial normalisation can introduce unnecessary warps.

Template image

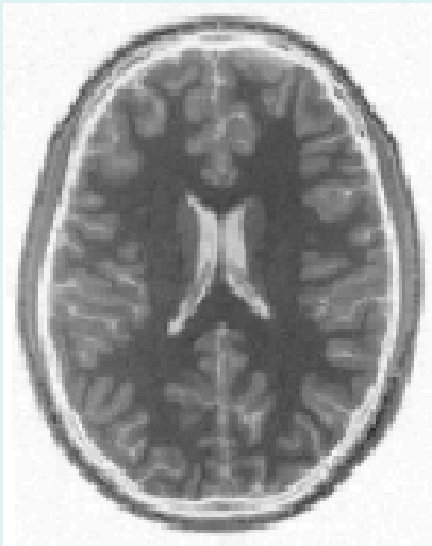

Affine registration.

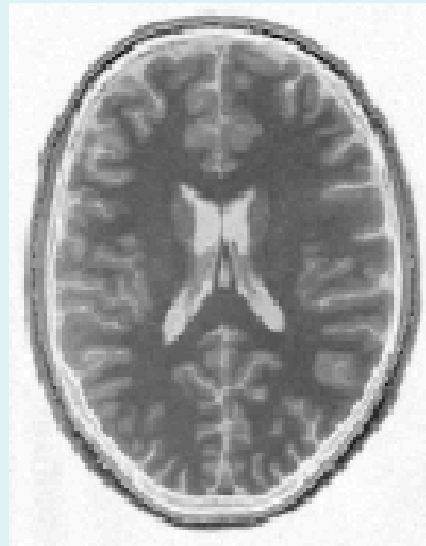

Non-linear registration without regularisation.

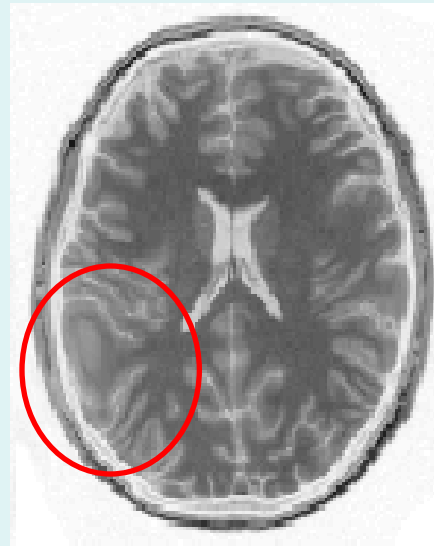

Non-linear registration using regularisation.

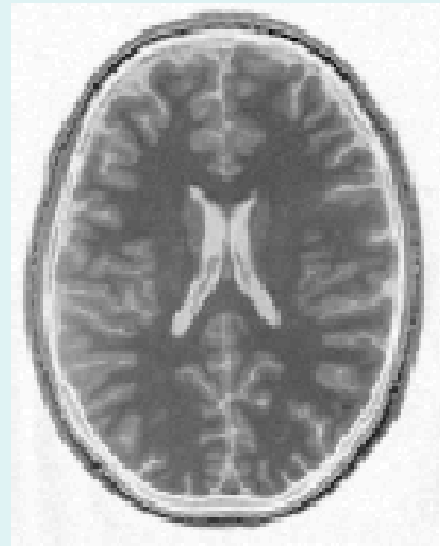

# Linear regularisation

- Some bias fields and distortions are more probable (a priori) than others.
- Encoded using Bayes rule:

$$-\log [P(\theta, \mathbf{y})] = -\log [P(\mathbf{y} | \theta)] - \log [P(\theta)]$$

- Prior probability distributions can be modelled by a multivariate normal distribution.
  - Mean vector  $\mu_a$  and  $\mu_b$
  - Covariance matrix  $\Sigma_a$  and  $\Sigma_b$
  - $-\log[P(\mathbf{a})] = (\mathbf{a} - \mathbf{m}_a)^T \mathbf{S}_a^{-1} (\mathbf{a} - \mathbf{m}_a) + \text{const}$



# Old fashioned template matching

Minimise mean squared difference from image to template image(s)

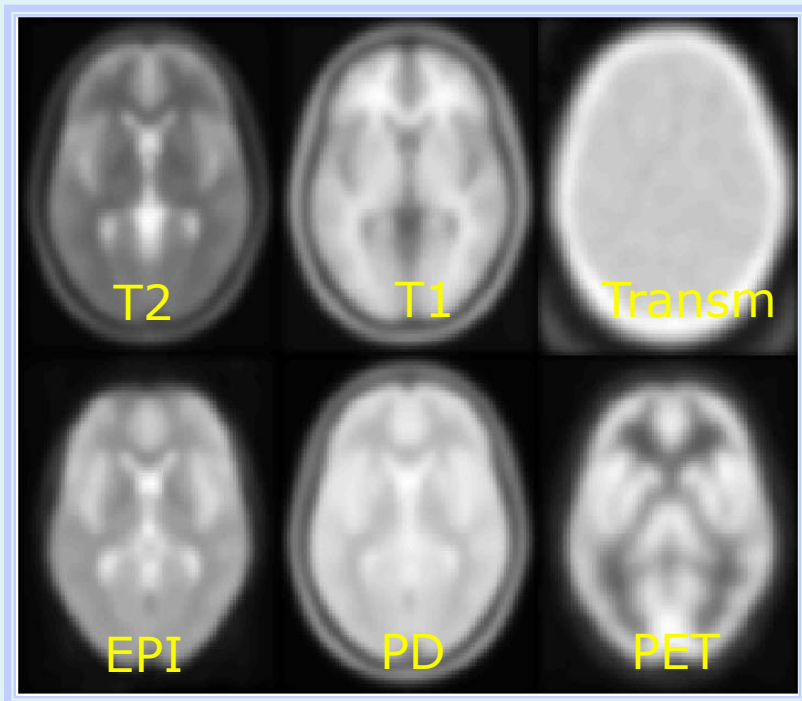

Template Images



Spatial normalisation can be weighted so that non-brain voxels do not influence the result.

Similar weighting masks can be used for normalising lesioned brains.

# Old fashioned template matching

Determine the spatial transformation that minimises the sum of squared difference between an image and a linear combination of one or more templates.

Begins with an affine registration to match the size and position of the image.

Followed by a global non-linear warping to match the overall brain shape.

Uses a Bayesian framework to simultaneously minimize the bending energies of the warps.

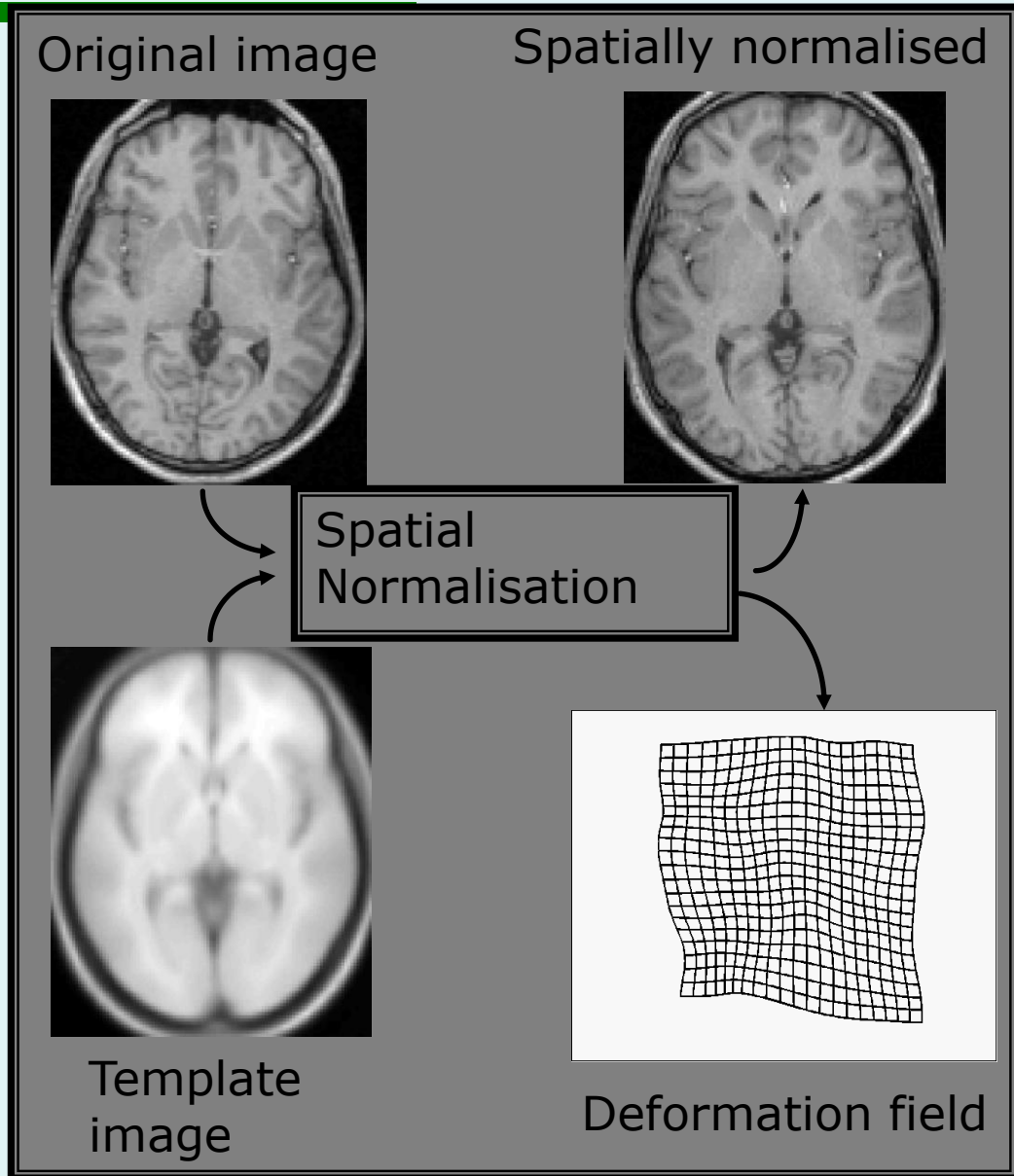

# Content

---

- **Preliminaries**
- **Within-subject**
- **Between-subject**
- **Smoothing**
- **Conclusion**

# Smoothing, principle

- Smoothing is done by convolution.
- Each voxel after smoothing effectively becomes the result of applying a weighted region of interest (ROI).
- Gaussian function, defined by its “*full width at half maximum*” (FWHM)

2D Gaussian function

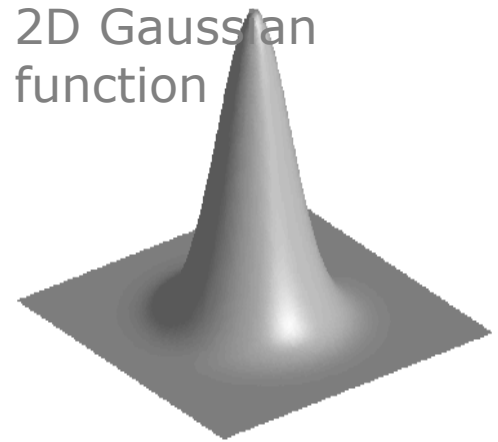

Before convolution

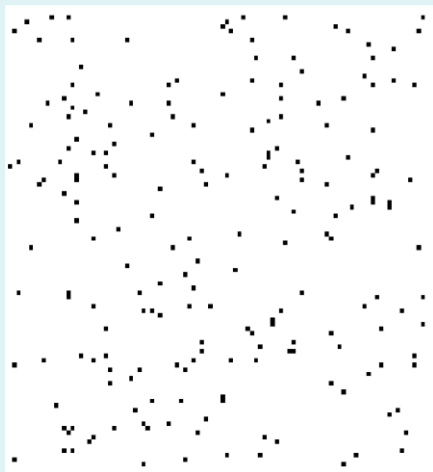

Convolved with a circle

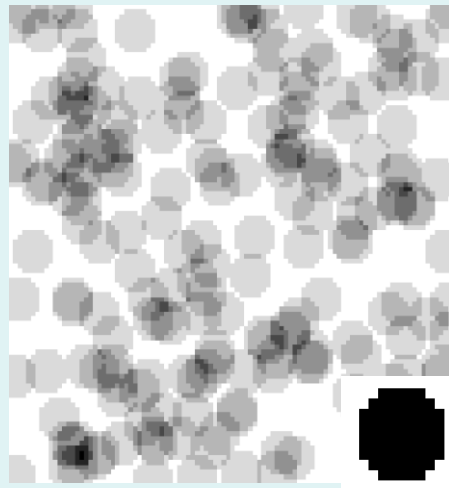

Convolved with a Gaussian

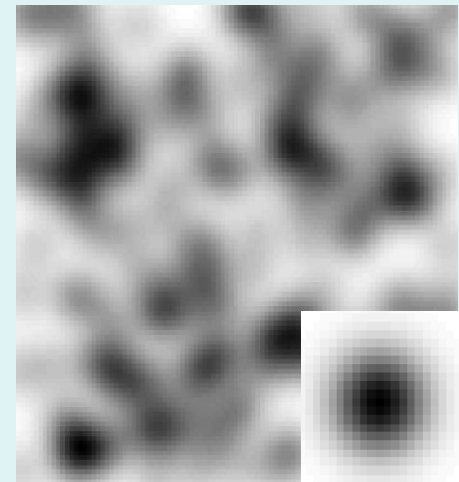

# Smoothing, why blur the data?

- Improves spatial overlap by blurring over minor anatomical differences and registration errors
- Averaging neighbouring voxels suppresses noise (matched filter theorem)
- Makes data more normally distributed (central limit theorem)
- Reduces the effective number of multiple comparisons

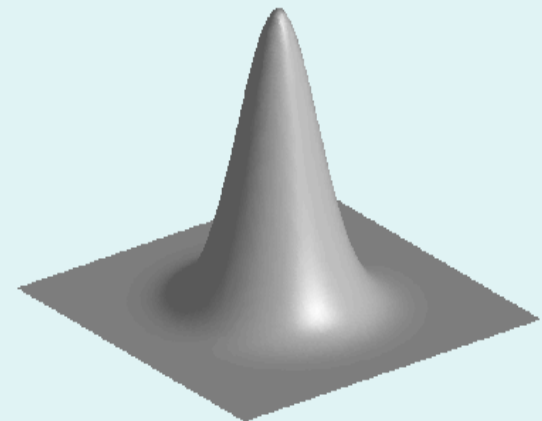

# Smoothing, kernel size

---

Decide *a priori*, based on:

- Population, i.e. noise & inter-subject variability
- Expected activation size

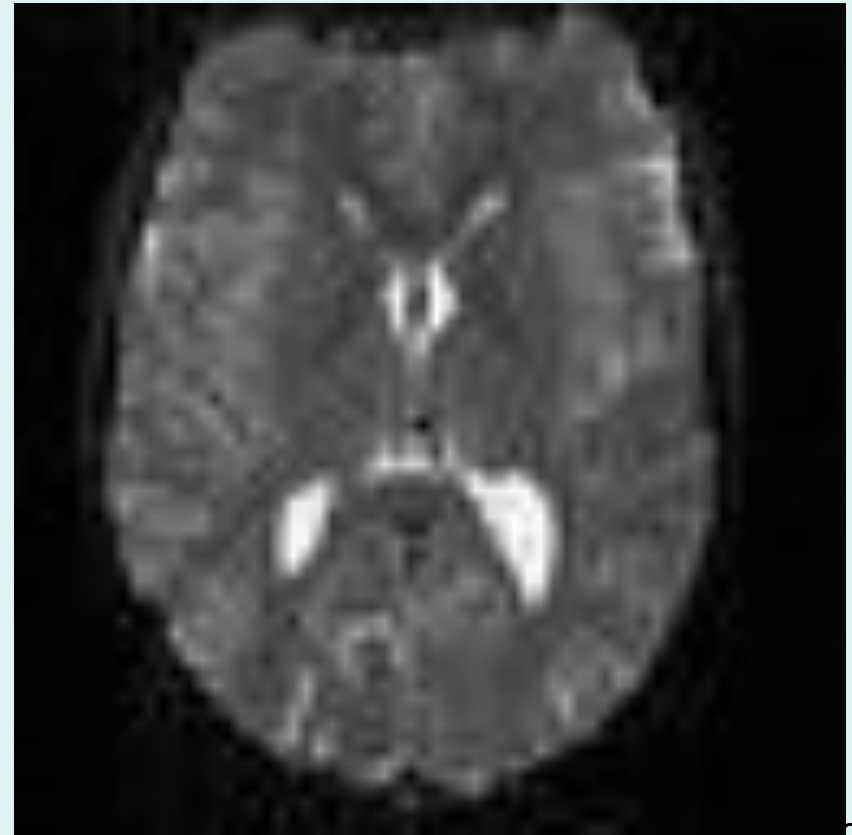
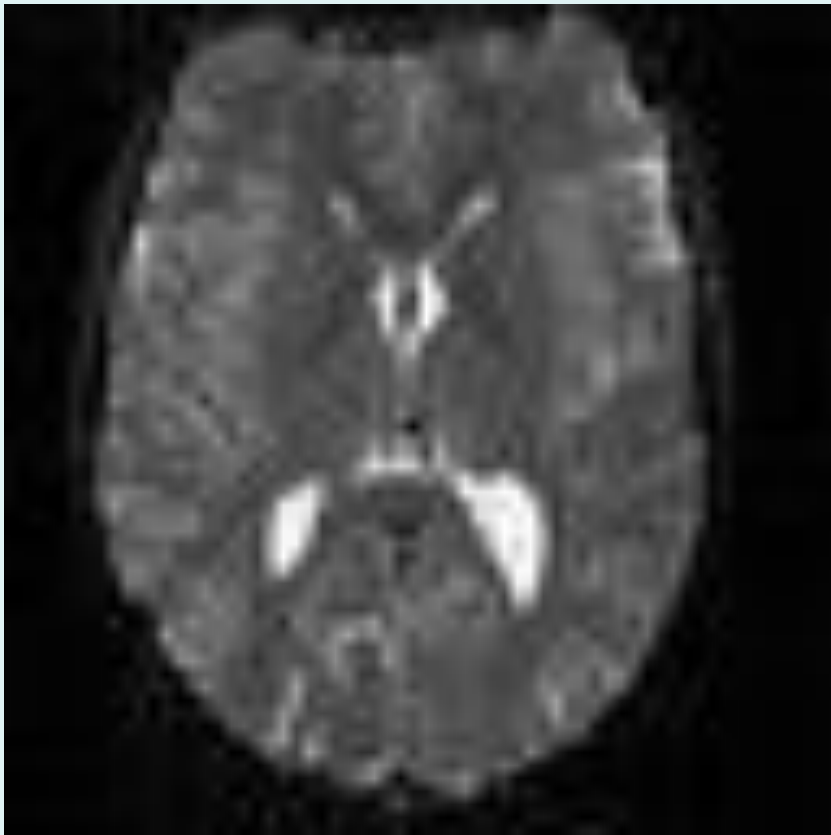

# Smoothing, kernel size

---

Decide *a priori*, based on:

- Population, i.e. noise & inter-subject variability
- Expected activation size

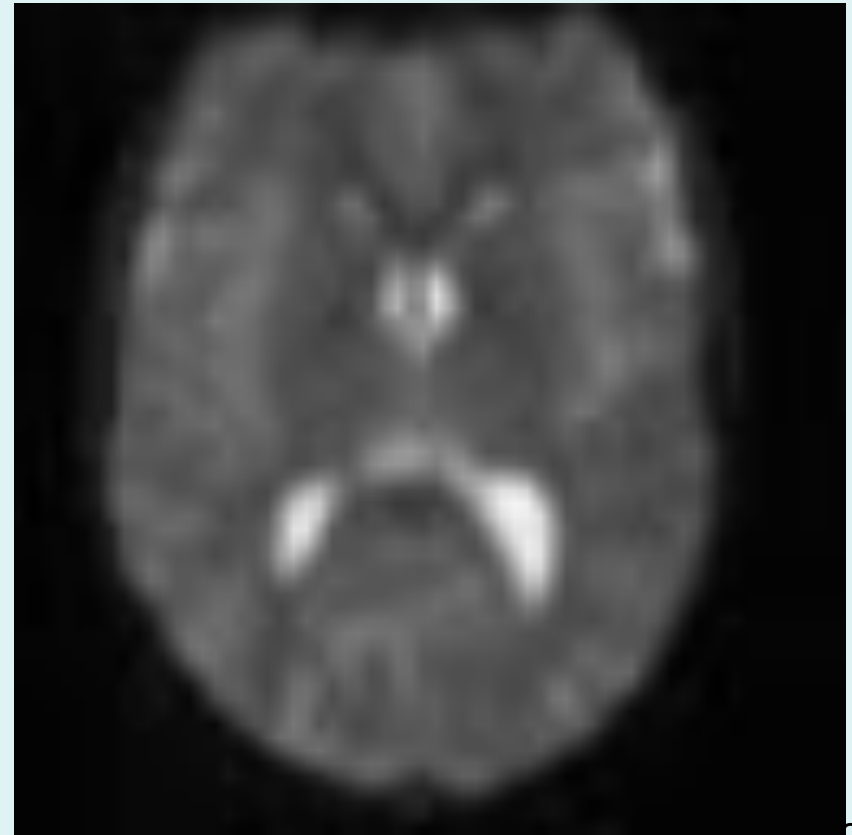
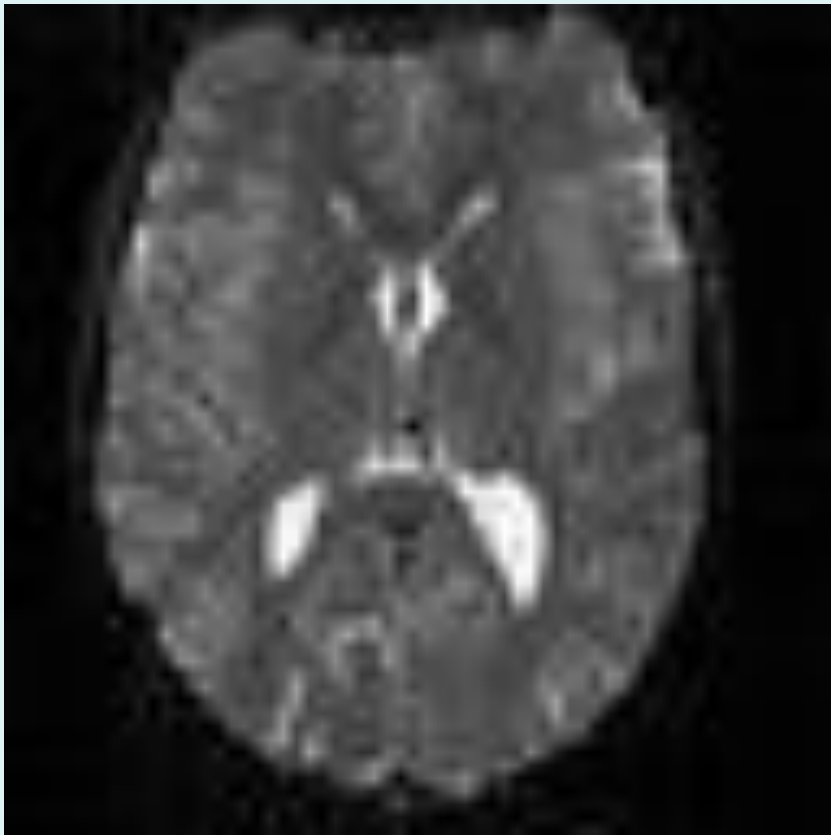

# Smoothing, kernel size

---

Decide *a priori*, based on:

- Population, i.e. noise & inter-subject variability
- Expected activation size

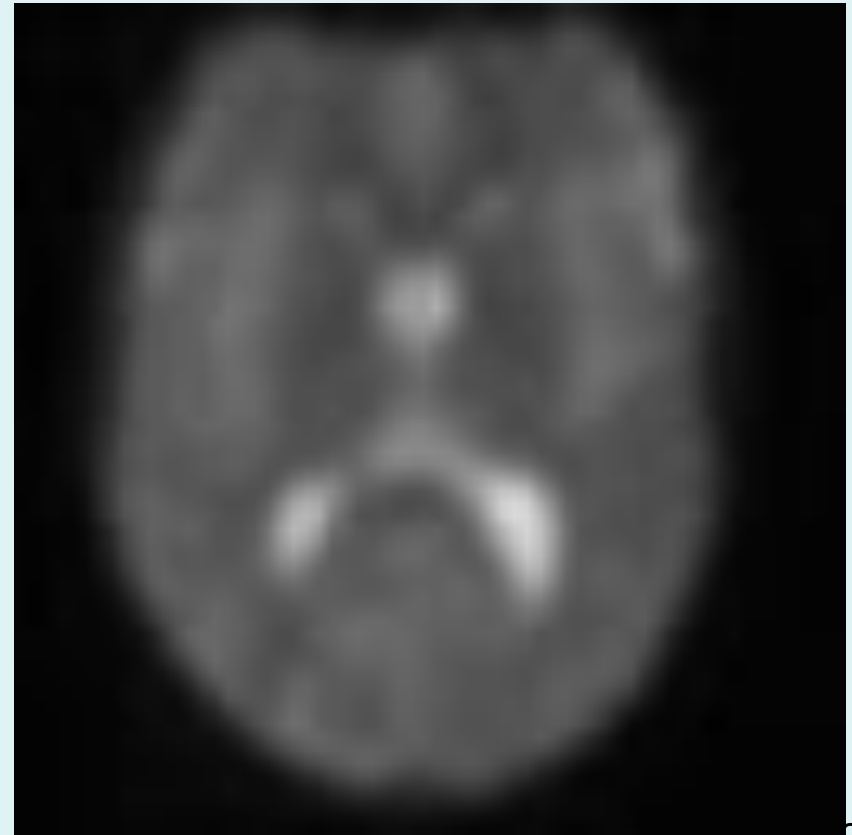
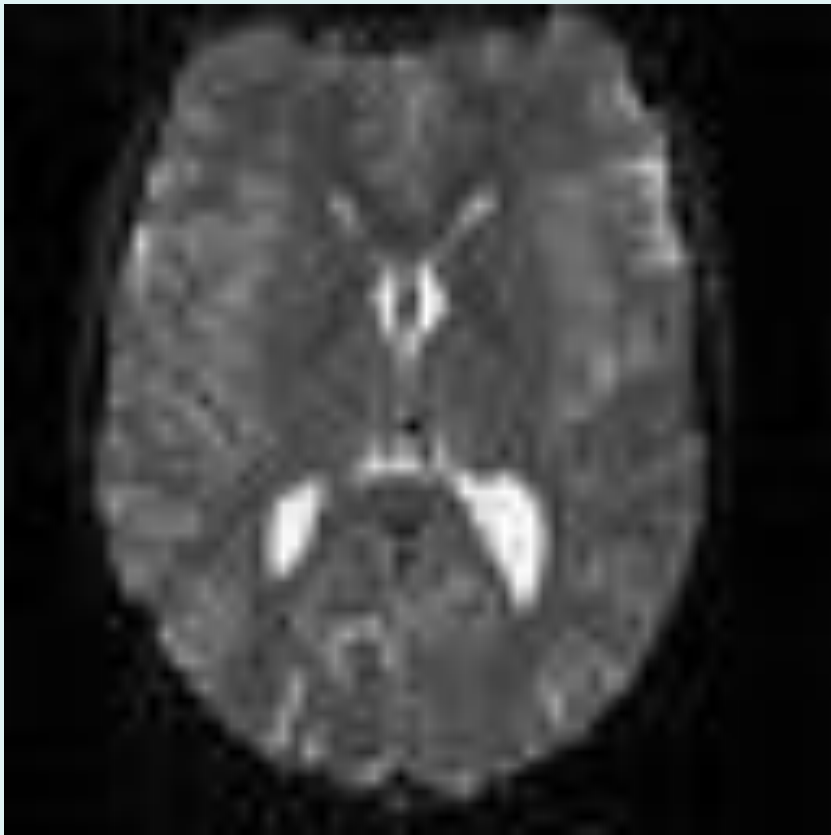



# Smoothing, kernel size

---

Decide *a priori*, based on:

- Population, i.e. noise & inter-subject variability
- Expected activation size

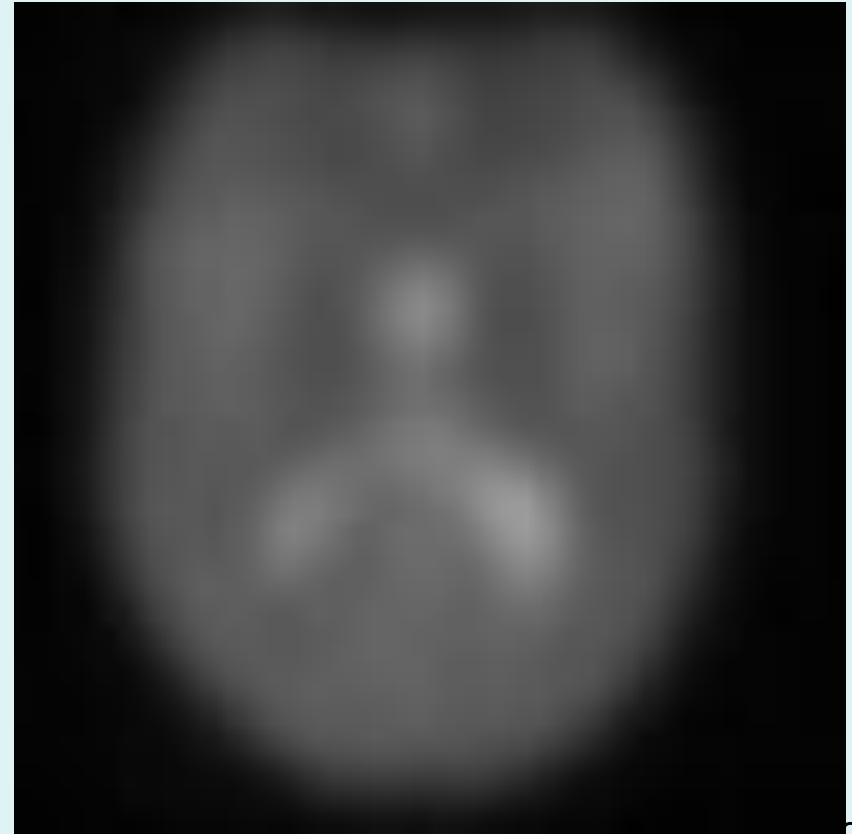
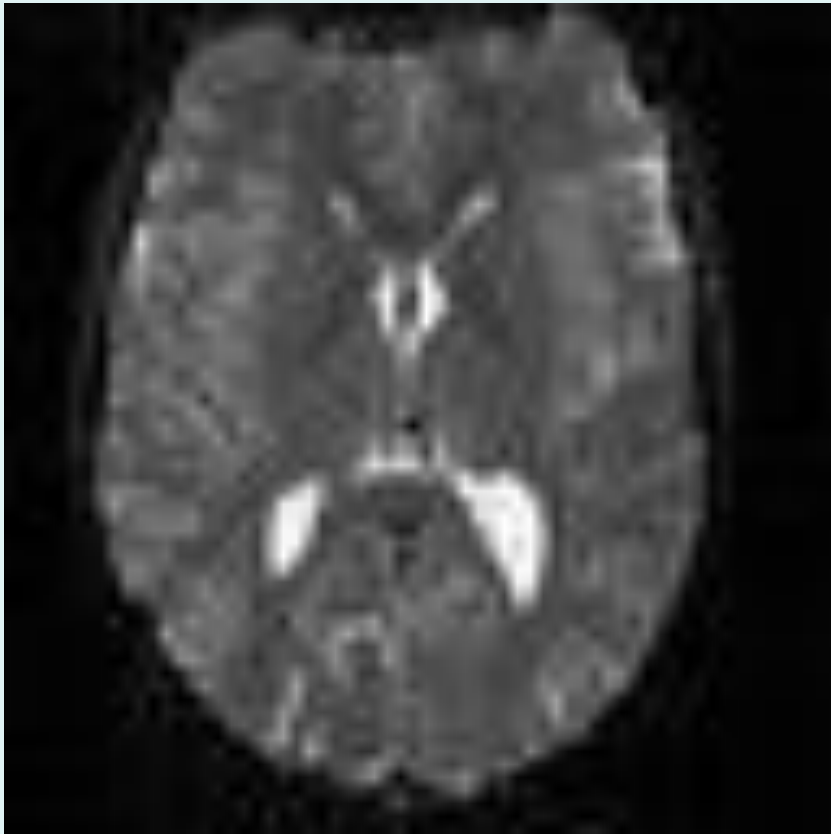

# Smoothing, kernel size

---

Decide *a priori*, based on:

- Population, i.e. noise & inter-subject variability
- Expected activation size

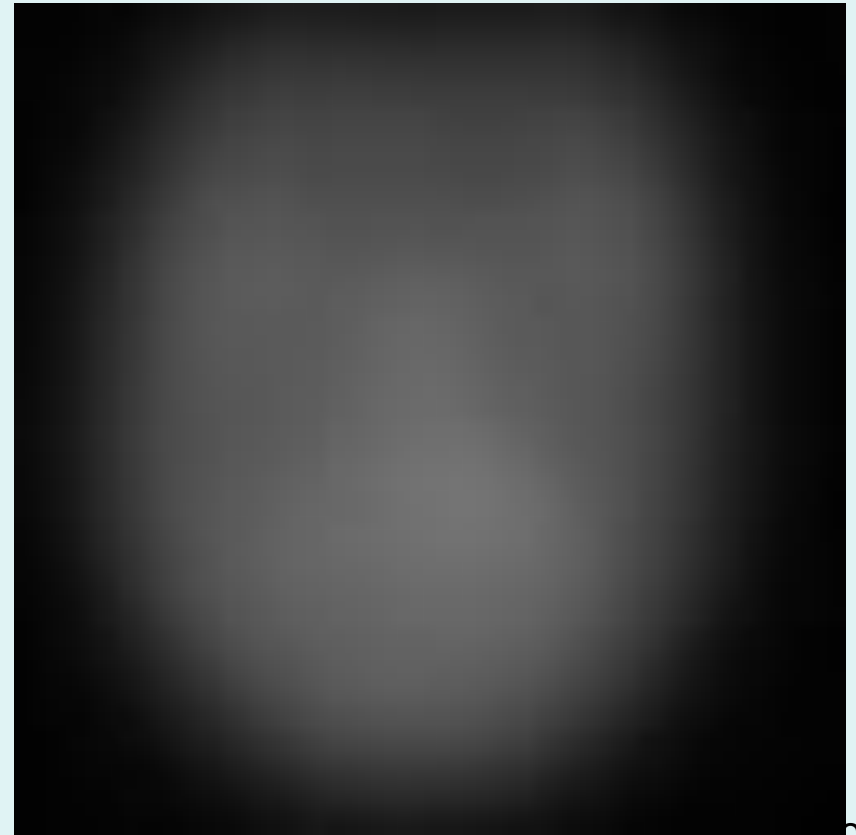
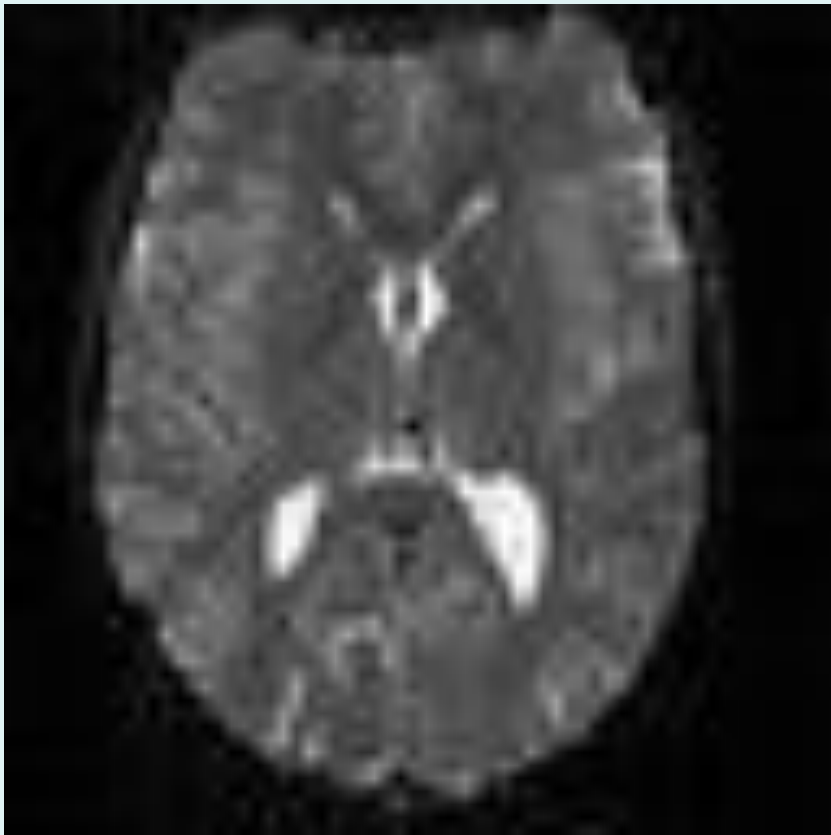

# Content

---

- **Preliminaries**
- **Within-subject**
- **Between-subject**
- **Smoothing**
- **Conclusion**

# Pre-processing overview

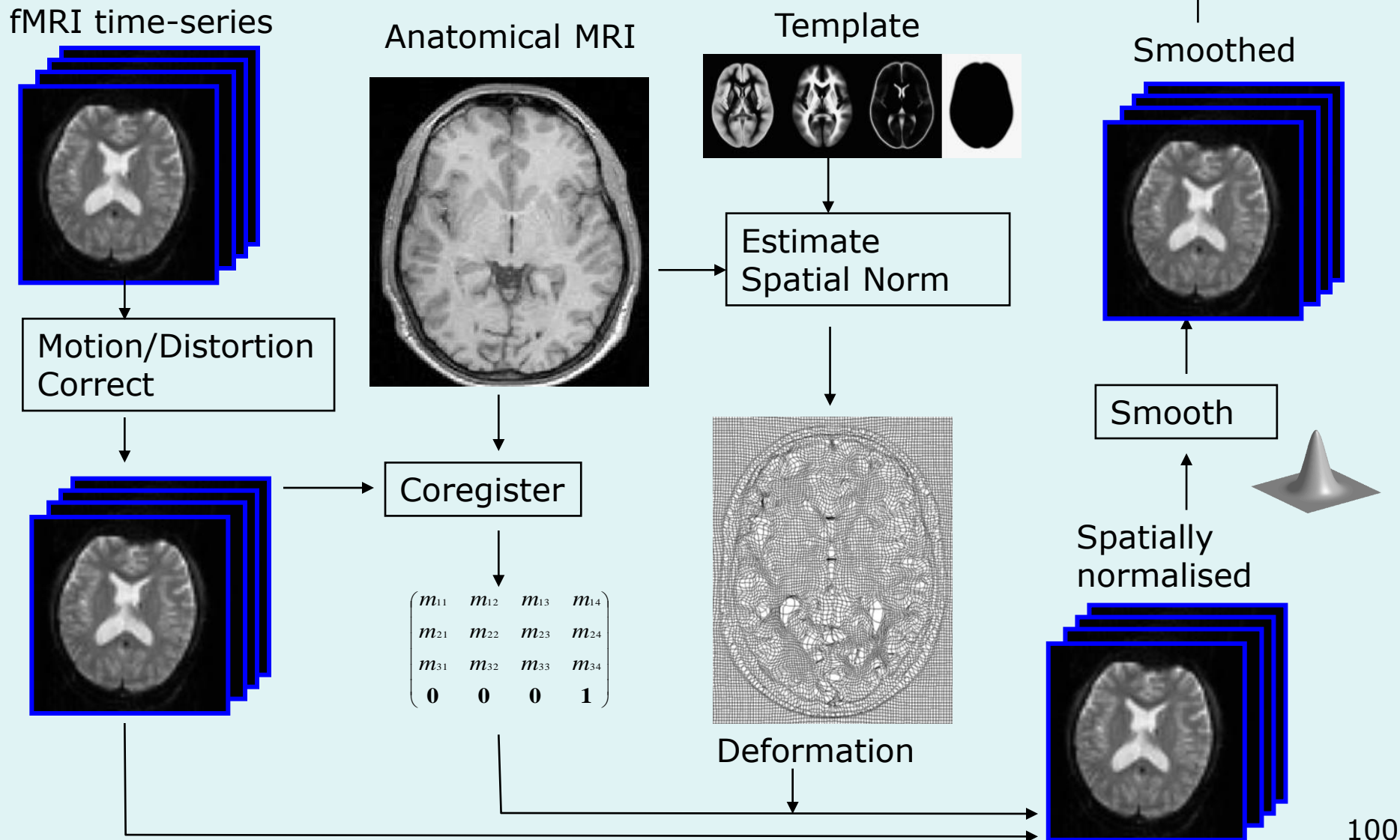

# Alternative pipeline

fMRI time-series

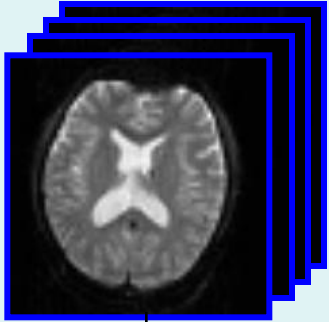

Motion/Distortion Correct

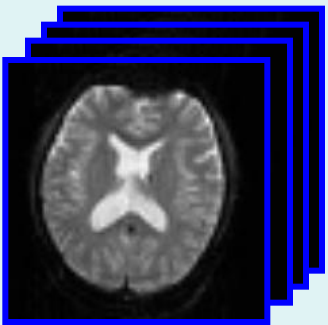

Template

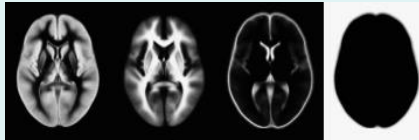

Estimate Spatial Norm

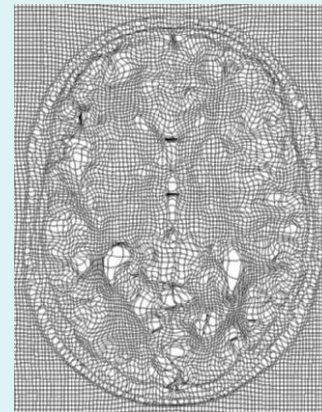

Deformation

Statistics or whatever

Smoothed

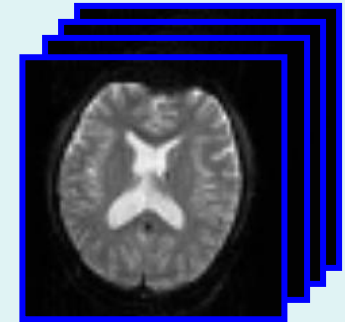

Smooth

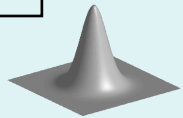

Spatially normalised

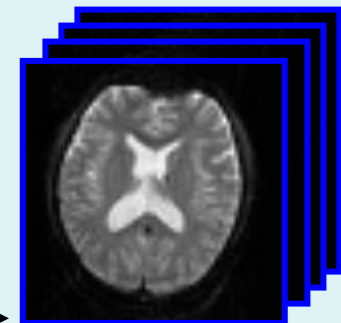

# References

---

- Friston et al. Spatial registration and normalisation of images. *Human Brain Mapping* 3:165-189 (1995).
- Collignon et al. Automated multi-modality image registration based on information theory. *IPMI'95* pp 263-274 (1995).
- Thévenaz et al. Interpolation revisited. *IEEE Trans. Med. Imaging* 19:739-758 (2000).
- Andersson et al. Modeling geometric deformations in EPI time series. *Neuroimage* 13:903-919 (2001).
- Hutton et al. Image distortion correction in fMRI: a quantitative evaluation. *NeuroImage* 16:217-240 (2002).
- Ashburner & Friston. Unified Segmentation. *NeuroImage* 26:839-851 (2005).

